

**CURTISS -
WRIGHT**

GTX Series Product Catalog

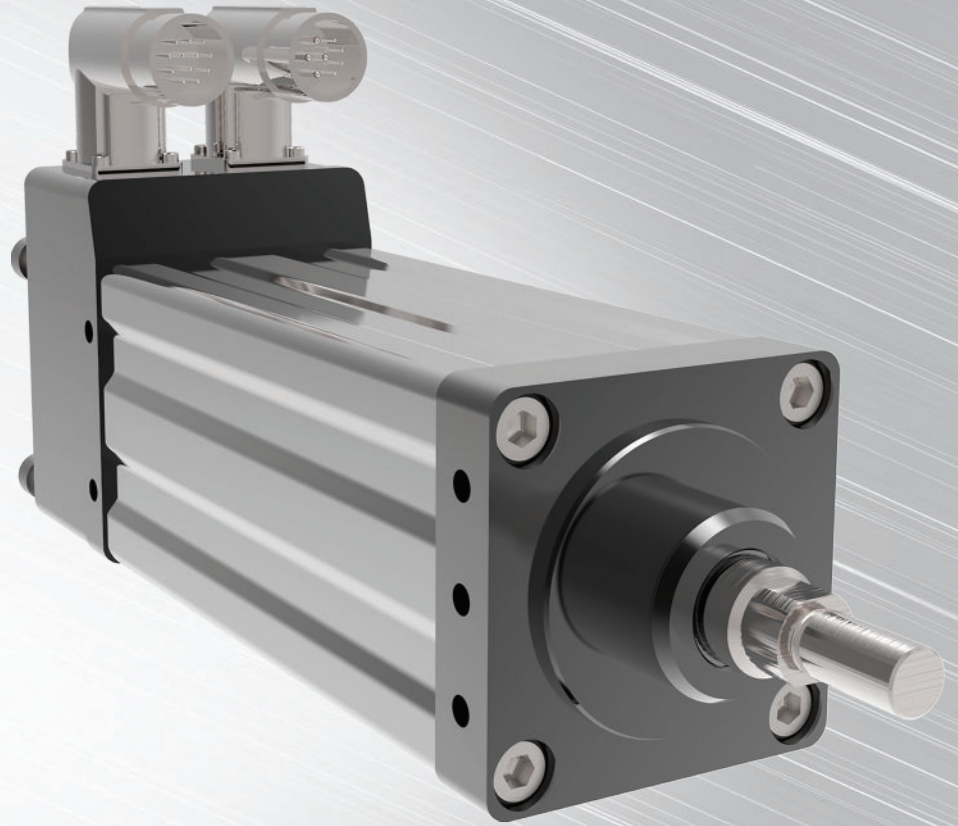

GTX Series

Description

For applications that require long life and continuous duty, even in harsh environments, the GTX Series actuator offers a robust solution. The life of these actuators can exceed that of a ball screw actuator by 15 times, all while delivering high speeds and high forces.

Operating Conditions and Usage		
Accuracy:		
Screw Lead Error	µm / 300 mm	25
	in/ft	0.001
Screw Travel Variation	µm / 300 mm	30
	in/ft	0.0012
Screw Lead Backlash	in	0.0006
	mm	0.01524
Ambient Operating Temperature	°C	0 to 25
	°F	0 to 77
Elevated Ambient Operating Temperature	°C	65*
	°F	149*
Friction Torque (typical)	Frame Size (Nm)	060 (0.12)
		080 (0.23)
		100 (0.34)
IP Rating		IP66S

* With derating

Elevated Ambient Temperature Operation

The speed/torque curves are based on 25° C ambient conditions. The actuators may be operated at ambient temperatures up to 65° C.

Elevated Ambient Temp Factor (%) =

$$100\% \times \sqrt{\frac{\text{Max Rated Temp } [\sim 130 \text{ } ^\circ\text{C}] - \text{Environment Temp } [\text{in } ^\circ\text{C}]}{\text{Max Rated Temp } [\sim 130 \text{ } ^\circ\text{C}] - \text{Rated Ambient } [\sim 25 \text{ } ^\circ\text{C}]}} =$$

$100\% \times \sqrt{\frac{130 \text{ } ^\circ\text{C} - \text{Environment Temp}}{105 \text{ } ^\circ\text{C}}}$	= % of published continuous @ 25 °C
---	-------------------------------------

Sealed for Long Life with Minimum Maintenance

GTX Series actuators have strong advantages wherever outside contaminants are an issue. In most rotary-to-linear devices, critical mechanisms are exposed to the environment. Thus, these actuators must be frequently inspected, cleaned and lubricated.

In contrast, the converting components in all Exlar GTX units are mounted within sealed motor housing. With a simple bushing and seal on the smooth extending rod, abrasive particles or other contaminants are prevented from reaching the actuator's critical mechanisms. This assures trouble-free operation even in the most harsh environments.

Agency Standards & Approvals		
UL		UL 1004-1
		UL 1004-6
CSA		CSA C22.2 NO. 100
CE	EMC	EN 55014-1
		EN 55014-2
	Safety	IEC/EN 60034-1
RoHS		RoHS 2011/65/EU and amended with directive 2015/863

Product Features

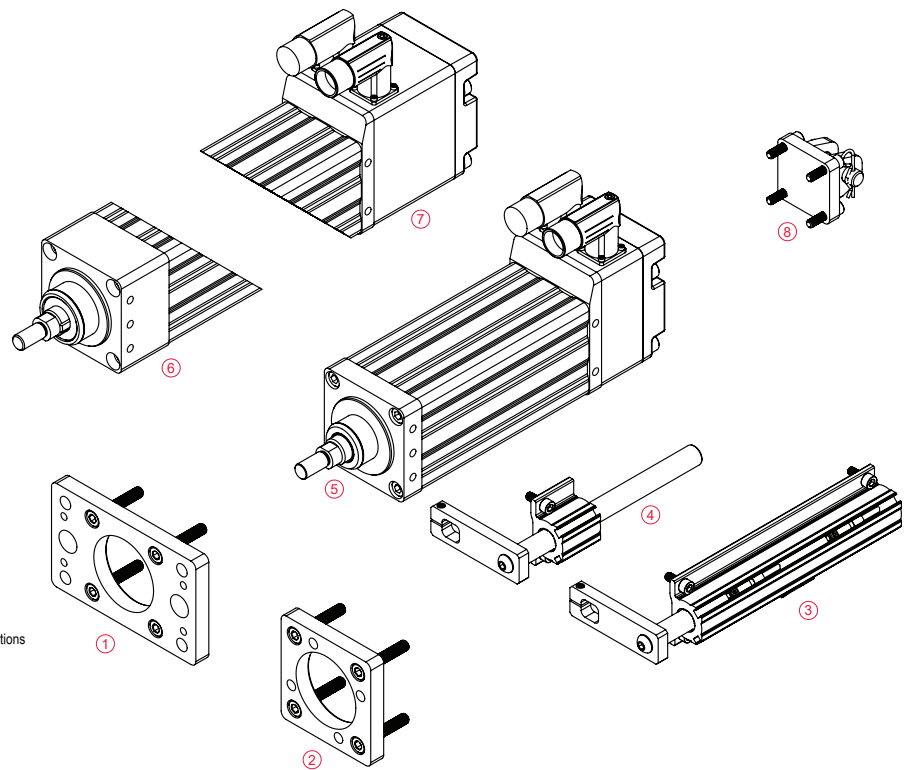
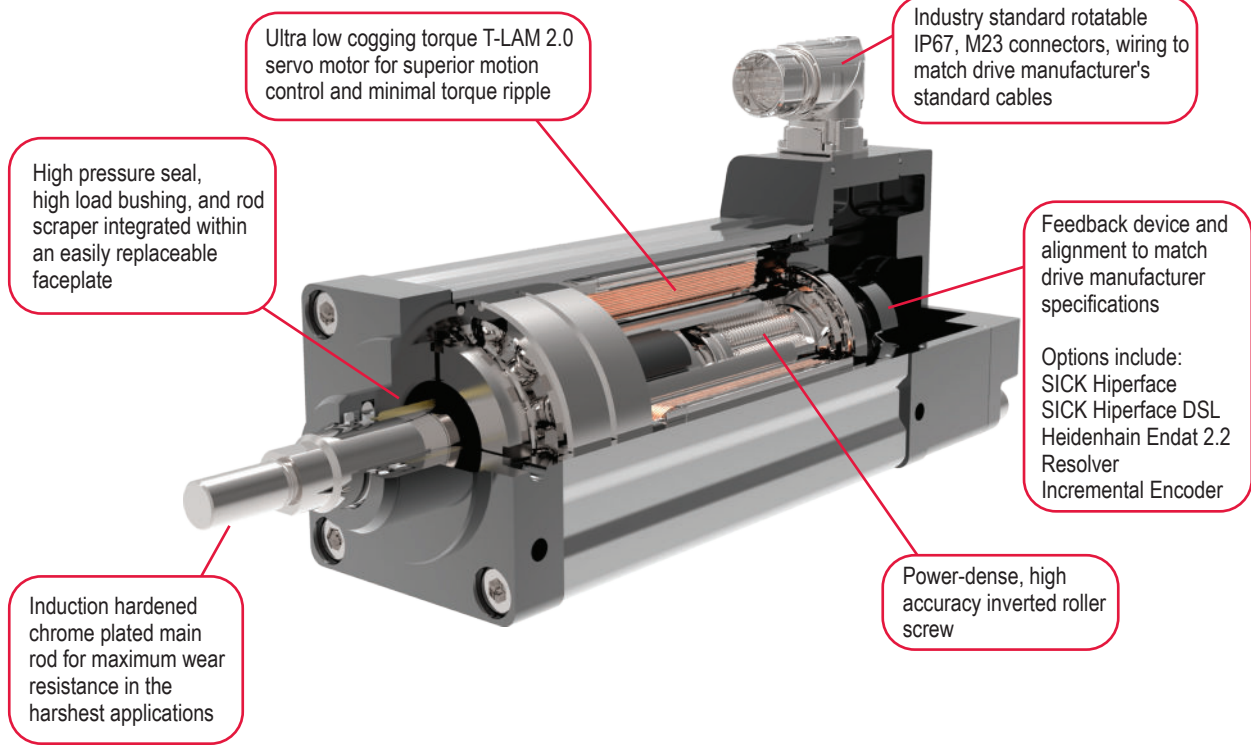

- 1 - Front Flange Kit*
 - 2 - Face Mount Kit
 - 3 - External Limit Switch Kit**
 - 4 - External Anti-Rotate Kit
 - 5 - Multiple Rod End Threads***
 - 6 - Internal Anti-Rotate (Splined Rod)***
 - 7 - Rear Brake Option
 - 8 - Rear Clevis Kit*
- * Metric/Imperial Options
 ** Limit Switches Sold Separately
 *** Male/Female and Metric/Imperial Options

Mechanical Specifications

GTX060

	Stroke Length mm (in)	Screw Lead mm (in)	Continuous Force Rating N (lbf)		Max Velocity mm/s (in/s)		Dynamic Load Rating N (lbf)	Armature Inertia kg-m ² (in-lb-s ²)	
			4 (Vac)	D (Vdc)	4 (Vac)	D (Vdc)			
GTX060-080-01	80 (3.2)	2.54 (0.1)	2,668 (600)	2,668 (600)	318 (12.5)	212 (8.3)	9,230 (2,075)	0.00007367 (0.000652)	
GTX060-080-02		5.08 (0.2)	1,900 (427)	1,610 (392)	635 (25.0)	423 (16.7)			6,850 (1,540)
GTX060-080-04		10.2 (0.4)	1,006 (226)	852 (192)	1,270 (50.0)	847 (33.3)			5,471 (1,230)
GTX060-150-01	150 (5.9)	2.54 (0.1)	2,668 (600)	2,668 (600)	318 (12.5)	212 (8.3)	9,230 (2,075)	0.00008689 (0.000769)	
GTX060-150-02		5.08 (0.2)	1,900 (427)	1,610 (392)	635 (25.0)	423 (16.7)			6,850 (1,540)
GTX060-150-04		10.2 (0.4)	1,006 (226)	852 (192)	1,270 (50.0)	847 (33.3)			5,471 (1,230)
GTX060-300-01	300 (11.8)	2.54 (0.1)	2,668 (600)	2,668 (600)	318 (12.5)	212 (8.3)	9,230 (2,075)	0.00011537 (0.001021)	
GTX060-300-02		5.08 (0.2)	1,900 (427)	1,610 (392)	635 (25.0)	423 (16.7)			6,850 (1,540)
GTX060-300-04		10.2 (0.4)	1,006 (226)	852 (192)	1,270 (50.0)	847 (33.3)			5,471 (1,230)

Maximum velocities listed at maximum voltages

Configured stroke lengths available in 25 mm increments. Consult Exlar sales representative.

Do not exceed 2X the continuous force rating during operation

Continuous force rating based upon 25 °C ambient conditions

GTX080

	Stroke Length mm (in)	Screw Lead mm (in)	Continuous Force Rating N (lbf)		Max Velocity mm/s (in/s)		Dynamic Load Rating N (lbf)	Armature Inertia kg-m ² (in-lb-s ²)	
			4 (Vac)	D (Vdc)	4 (Vac)	D (Vdc)			
GTX080-100-01	100 (3.9)	2.54 (0.1)	8,365 (1,881)	7,101 (1,596)	254 (10.0)	102 (4.0)	24,535 (5,516)	0.000340 (0.003013)	
GTX080-100-02		5.08 (0.2)	4,740 (1,066)	4,024 (905)	508 (20.0)	203 (8.0)			25,798 (5,800)
GTX080-100-05		12.7 (0.5)	2,008 (451)	1,704 (383)	1,270 (50.0)	508 (20.0)			21,795 (4,900)
GTX080-150-01	150 (5.9)	2.54 (0.1)	8,365 (1,881)	7,101 (1,596)	254 (10.0)	102 (4.0)	24,535 (5,516)	0.000369 (0.003267)	
GTX080-150-02		5.08 (0.2)	4,740 (1,066)	4,024 (905)	508 (20.0)	203 (8.0)			25,798 (5,800)
GTX080-150-05		12.7 (0.5)	2,008 (451)	1,704 (383)	1,270 (50.0)	508 (20.0)			21,795 (4,900)
GTX080-300-01	300 (11.8)	2.54 (0.1)	8,365 (1,881)	7,101 (1,596)	254 (10.0)	102 (4.0)	24,535 (5,516)	0.000455 (0.004029)	
GTX080-300-02		5.08 (0.2)	4,740 (1,066)	4,024 (905)	508 (20.0)	203 (8.0)			25,798 (5,800)
GTX080-300-05		12.7 (0.5)	2,008 (451)	1,704 (383)	1,270 (50.0)	508 (20.0)			21,795 (4,900)
GTX080-450-01	450 (17.7)	2.54 (0.1)	8,365 (1,881)	7,101 (1,596)	254 (10.0)	102 (4.0)	24,535 (5,516)	0.000541 (0.004790)	
GTX080-450-02		5.08 (0.2)	4,740 (1,066)	4,024 (905)	508 (20.0)	203 (8.0)			25,798 (5,800)
GTX080-450-05		12.7 (0.5)	2,008 (451)	1,704 (383)	1,270 (50.0)	508 (20.0)			21,795 (4,900)

Maximum velocities listed at maximum voltages

Configured stroke lengths available in 25 mm increments. Consult Exlar sales representative.

Do not exceed 2X the continuous force rating during operation

Continuous force rating based upon 25 °C ambient conditions

GTX100

	Stroke Length mm (in)	Screw Lead mm (in)	Continuous Force Rating N (lbf)	Max Velocity mm/s (in/s)	Dynamic Load Rating N (lbf)	Armature Inertia kg-m ² (in-lb-s ²)
			4 (Vac)	4 (Vac)		
GTX100-150-01	150 (5.9)	2.54 (0.1)	15,392 (3,460)	191 (7.5)	54,557 (12,266)	0.0014085 (0.012467)
GTX100-150-02		5.08 (0.2)	12,098 (2,720)	381 (15.0)	55,972 (12,584)	
GTX100-150-05		12.7 (0.5)	5,444 (1,224)	953 (37.5)	37,141 (8,350)	
GTX100-300-01	300 (11.8)	2.54 (0.1)	15,392 (3,460)	191 (7.5)	54,557 (12,266)	0.0017399 (0.015399)
GTX100-300-02		5.08 (0.2)	12,098 (2,720)	381 (15.0)	55,972 (12,584)	
GTX100-300-05		12.7 (0.5)	5,444 (1,224)	953 (37.5)	37,141 (8,350)	

Maximum velocities listed at maximum voltages
Configured stroke lengths available in 25 mm increments. Consult Exlar sales representative.

Do not exceed 2X the continuous force rating during operation
Continuous force rating based upon 25 °C ambient conditions

Estimated Service Life

GTX060

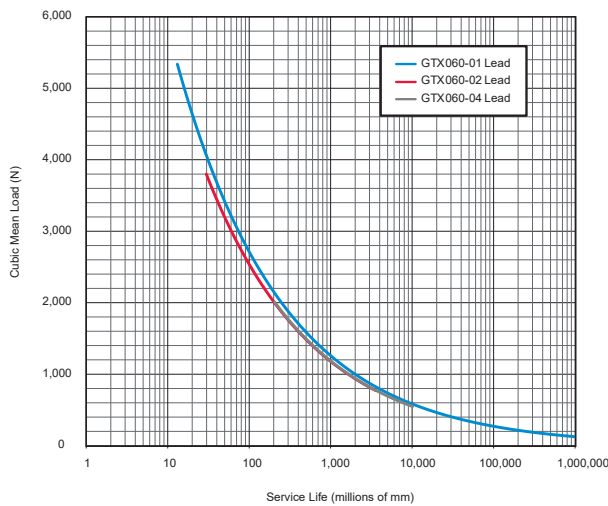

GTX080

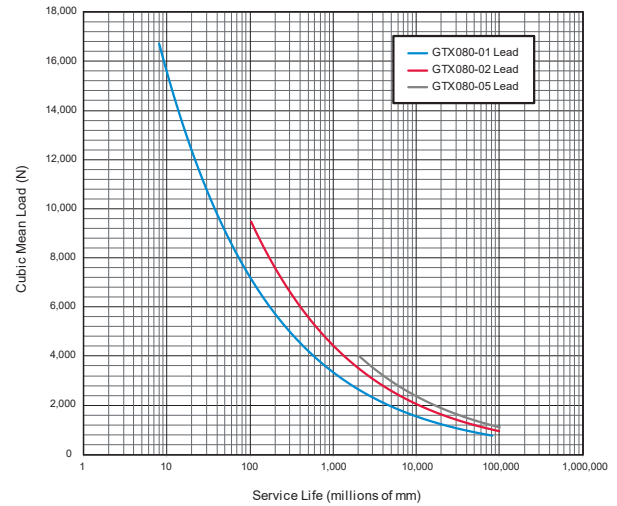

GTX100

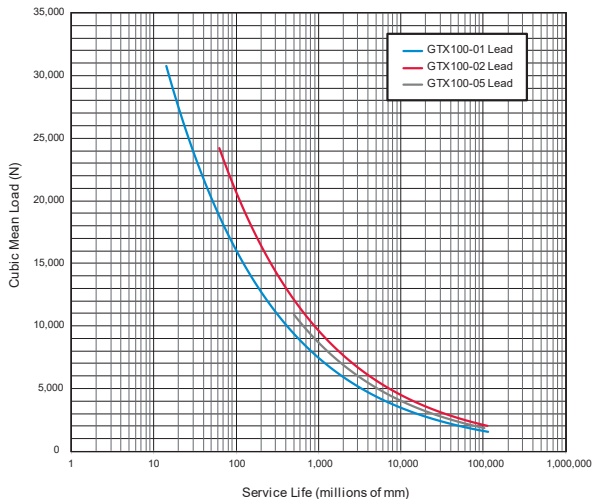

Service Life Estimate Assumptions:

- Sufficient quality and quantity of lubrication is maintained throughout service life.
- No mechanical hard stops (external or internal) or impact loads
- No external side loads
- Does not apply to short stroke, high frequency applications such as fatigue testing or short stroke, high force applications such as pressing. If your application requires high force over a stroke length shorter than the length of the rollers/nut, please contact Exlar for additional details on calculating estimated service life. You may also download the article "Calculating Life Expectancy" at www.cw-actuation.com.

The L_{10} expected life of a roller screw linear actuator is expressed as the linear travel distance that 90% of properly maintained roller screws manufactured are expected to meet or exceed. This is not a guarantee and these charts should be used for estimation purposes only.

The underlying formula that defines this value is:
Travel life in millions of inches, where:

$$L_{10} = \left(\frac{C_a}{F_{cml}} \right)^3 \times \ell$$

C_a = Dynamic load rating (lbf)
 F_{cml} = Cubic mean applied load (lbf)
 ℓ = Roller screw lead (inches)

For additional details on calculating estimated service life, please refer www.cw-actuation.com.

Electrical Specifications

GTX060

Motor Voltage		4 (AC)			D (DC)		
Max Bus Voltage		230/460 Vac			24/48 Vdc		
Speed @ Bus Voltage	rpm	5000/7500			2400/5000		
Actuator Lead	in	0.1	0.2	0.4	0.1	0.2	0.4
RMS Sinusoidal Commutation							
Continuous Motor Torque	Nm	1.35	1.81	1.81	1.35	1.53	1.53
	lbf-in	11.9	16.0	16.0	11.9	13.6	13.6
Continuous Current Rating	A	3.0	4.0	4.0	18.3	20.8	20.8
Peak Current Rating	A	6.0	8.0	8.0	36.7	41.7	41.7
Torque Constant (Kt) (±10% @ 25 °C)	Nm/A	0.5			0.08		
	lbf-in/A	4.5			0.7		
Voltage Constant (Ke) (± 10% @ 25 °C)	V/krpm	30.5			5.0		
0 - Peak Sinusoidal Commutation							
Continuous Motor Torque	Nm	1.81			1.5		
	lbf-in	16			13.6		
Continuous Current Rating	A	5.7			29.5		
Peak Current Rating	A	11.3			58.9		
Torque Constant (Kt) (± 10% @ 25 °C)	Nm/A	0.35			0.06		
	lbf-in/A	3.2			0.5		
Voltage Constant (Ke) (± 1% @ 25 °C)	V/krpm	43.1			7.0		
Pole Configuration	Number of Poles	8			8		
Resistance (L-L) (± 5% @ 25 °C)	Ohms	2.8			0.1		
Inductance (L-L)(± 15%)	mH	13.8			0.3		
Electrical Time Constant	ms	4.9			3.1		
Insulation Class		460 Vac Max, 180 °C (Class H)					

Specifications subject to change without notice

Test data derived using NEMA recommended aluminum heatsink 10" x 10" x 1/4" at 25 °C ambient

Vac Class winding operational compatible with drive voltages up to 460 Vac

Vdc Class winding operational compatible with drive voltages up to 48 Vdc

Rotational speed approximately proportional to drive input voltage

GTX060 Weights	
Description	kg (lb)
GTX060-80	3.2 (7.0)
GTX060-150	3.7 (8.1)
GTX060-300	4.8 (10.5)
Brake Adder	0.7 (1.4)
Front Flange (1)	0.4 (0.9)
Tapped Face (3)	0.3 (0.5)
Rear Clevis (5)	0.2 (0.5)
Imperial Flange (F)	0.3 (0.7)
Imperial Clevis (C)	0.3 (0.7)
Anti Rotate (80 mm stroke)	0.46 (1.0)
Anti Rotate (150 mm stroke)	0.54 (1.2)
Anti Rotate (300 mm stroke)	0.72 (1.6)
Limit Switch Assembly w/Anti-Rotate (80 mm stroke)	0.67 (1.5)
Limit Switch Assembly w/Anti-Rotate (150 mm stroke)	0.81 (1.8)
Limit Switch Assembly w/Anti-Rotate (300 mm stroke)	1.11 (2.5)

Brake Specifications		
Brake Holding Torque (minimum)	Nm	2.5
	lbf-in	22
Brake Voltage	Vdc	24 (-10%/+6%)
Nominal Brake Current at 24 Vdc	A	0.46
Brake Engage/Disengage Time (typical)	ms	10/25

GTX080

Motor Voltage		4 (AC)	D (DC)
Max Bus Voltage		230/460 Vac	24/48 Vdc
Speed @ Bus Voltage	rpm	3000/6000	1000/2400
RMS Sinusoidal Commutation			
Continuous Motor Torque	Nm	4.51	3.83
	lbf-in	39.9	33.9
Continuous Current Rating	A	4.9	24.2
Peak Current Rating	A	9.9	48.5
Torque Constant (Kt) (± 10% @ 25 °C)	Nm/A	1.02	0.18
	lbf-in/A	9.0	1.6
Voltage Constant (Ke) (± 10% @ 25 °C)	V/krpm	61.6	10.7
0 - Peak Sinusoidal Commutation			
Continuous Motor Torque	Nm	4.51	3.83
	lbf-in	39.9	33.9
Continuous Current Rating	A	6.6	34.6
Peak Current Rating	A	13.3	69.2
Torque Constant (Kt) (± 10% @ 25 °C)	Nm/A	0.72	0.13
	lbf-in/A	6.4	1.1
Voltage Constant (Ke) (± 10% @ 25 °C)	V/krpm	87.1	15.1
Pole Configuration	Number of Poles	8	8
Resistance (L-L) (± 5% @ 25 °C)	Ohms	2.5	0.1
Inductance (L-L)(±15%)	mH	17.3	0.46
Electrical Time Constant	ms	6.8	6.9
Insulation Class	460 Vac Max, 180 °C (Class H)		

Specifications subject to change without notice

Test data derived using NEMA recommended aluminum heatsink 10" x 10" x 1/4" at 25 °C ambient

Vac Class winding operational compatible with drive voltages up to 460 Vac

Vdc Class winding operational compatible with drive voltages up to 48 Vdc

Rotational speed approximately proportional to drive input voltage

GTX080 Weights	
Description	kg (lb)
GTX080-100	6.1 (13.5)
GTX080-150	6.8 (14.9)
GTX080-300	8.6 (19.0)
GTX080-450	10.5 (23.1)
Brake Adder	1.1 (2.5)
Front Flange (1)	1.0 (2.2)
Tapped Face (3)	0.6 (1.2)
Rear Clevis (5)	0.4 (0.8)
Imperial Flange (F)	0.8 (1.8)
Imperial Clevis (C)	0.8 (1.7)
Anti Rotate (100 mm stroke)	0.5 (1.1)
Anti Rotate (150 mm stroke)	0.6 (1.3)
Anti Rotate (300 mm stroke)	0.8 (1.8)
Anti Rotate (450 mm stroke)	1.1 (2.4)
Limit Switch Assembly w/Anti-Rotate (100 mm stroke)	0.9 (1.9)
Limit Switch Assembly w/Anti-Rotate (150 mm stroke)	1.0 (2.3)
Limit Switch Assembly w/Anti-Rotate (300 mm stroke)	1.6 (3.5)
Limit Switch Assembly w/Anti-Rotate (450 mm stroke)	2.1 (4.7)

Brake Specifications		
Brake Holding Torque (minimum)	Nm	4.5
	lbf-in	40
Brake Voltage	Vdc	24 (-10%/+6%)
Nominal Brake Current at 24 Vdc	A	0.5
Brake Engage/Disengage Time (typical)	ms	18/35

GTX100

Motor Voltage		4 (AC)
Max Bus Voltage		230/460 Vac
Speed @ Bus Voltage	rpm	3000/4500
RMS Sinusoidal Commutation		
Continuous Motor Torque	Nm	12.23
	lbf-in	108.2
Continuous Current Rating*	A	12.3
Peak Current Rating*	A	24.7
Torque Constant (Kt) (± 10% @ 25 °C)	Nm/A	1.11
	lbf-in/A	9.8
Voltage Constant (Ke) (± 10% @ 25 °C)	V/krpm	67.0
0 - Peak Sinusoidal Commutation		
Continuous Motor Torque	Nm	12.23
	lbf-in	108.2
Continuous Current Rating	A	17.4
Peak Current Rating	A	34.8
Torque Constant (Kt) (± 10% @ 25 °C)	Nm/A	0.78
	lbf-in/A	6.92
Voltage Constant (Ke) (± 10% @ 25 °C)	V/krpm	94.8
Pole Configuration	Number of Poles	8
Resistance (L-L) (± 5% @ 25 °C)	Ohms	0.65
Inductance (L-L)(± 15%)	mH	4.9
Electrical Time Constant	ms	7.6
Insulation Class	460 Vac Max, 180 °C (Class H)	

Specifications subject to change without notice

Test data derived using NEMA recommended aluminum heatsink 12" x 12" x 1/2" at 25 °C ambient

Vac Class winding operational compatible with drive voltages up to 460 Vac

Rotational speed approximately proportional to drive input voltage

* For actuators with a 0.1" lead, the torque and current must be limited to 8.89 Nm/9.0 A not to exceed the continuous force rating specified in the mechanical specifications table on page 6. Peak torque and current values would be 2x the continuous values

GTX100 Weights	
Description	kg (lb)
GTX100-150	13.1 (28.8)
GTX100-300	16.0 (35.2)
Brake Adder	1.2 (2.7)
Front Flange (1)	2.2 (4.7)
Tapped Face (3)	1.1 (2.4)
Rear Clevis (5)	0.8 (1.8)
Imperial Flange (F)	1.9 (4.1)
Imperial Clevis (C)	1.1 (2.5)
Anti Rotate (150 mm stroke)	1.5 (3.2)
Anti Rotate (300 mm stroke)	2.0 (4.5)
Limit Switch Assembly w/Anti-Rotate (150 mm stroke)	2.0 (4.5)
Limit Switch Assembly w/Anti-Rotate (300 mm stroke)	2.8 (6.2)

Brake Specifications		
Brake Holding Torque (minimum)	Nm	11
	lbf-in	97
Brake Voltage	Vdc	24 (-10%/+6%)
Nominal Brake Current at 24 Vdc	A	0.75
Brake Engage/Disengage Time (typical)	ms	25/40

Speed vs. Force Curves

These charts represent typical linear speed versus linear force curves for the GTX actuators using common brushless motor amplifiers. The GTX Series are compatible with many different brushless motor amplifiers; any differences in the performance

ratings of these amplifiers can alter the actuator's performance. Thus, the curves below should be used for estimation only. (Further information is available by contacting your local sales representative.)

AC Voltage Winding

GTX060 - 01

2.54 mm (0.1 in) Screw Lead

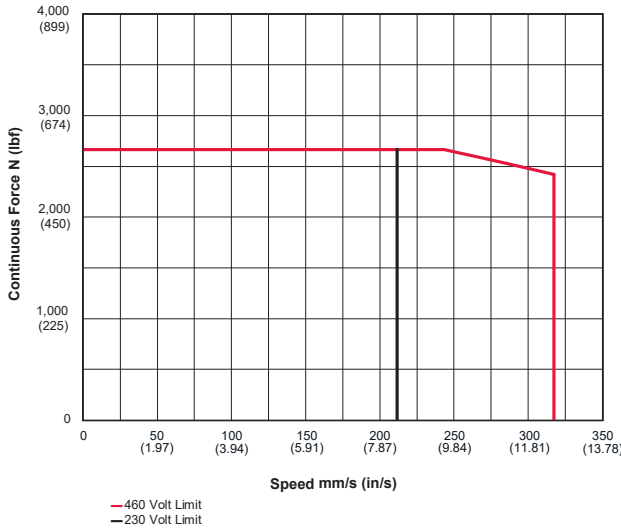

GTX060 0- 04

10.16 mm (0.4 in) Screw Lead

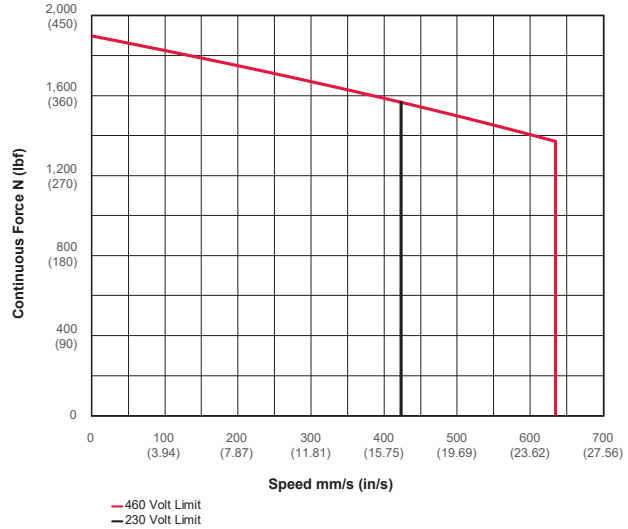

GTX060 - 02

5.08 mm (0.2 in) Screw Lead

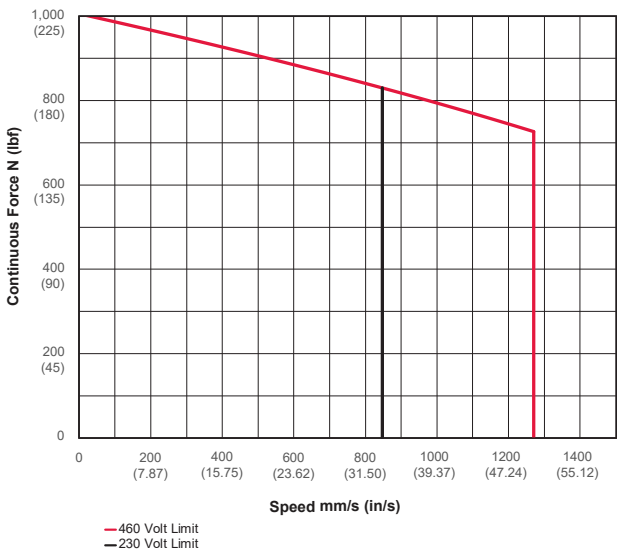

Test data derived using NEMA recommended aluminum heatsink 10" x 10" x 1/4" for GTX080.

DC Voltage Winding

GTX060 - 01
2.54 mm (0.1 in) Screw Lead

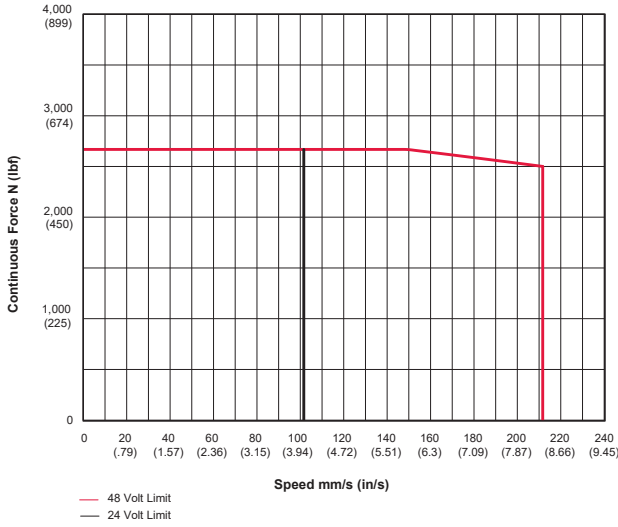

GTX060 - 04
10.16 mm (0.4 in) Screw Lead

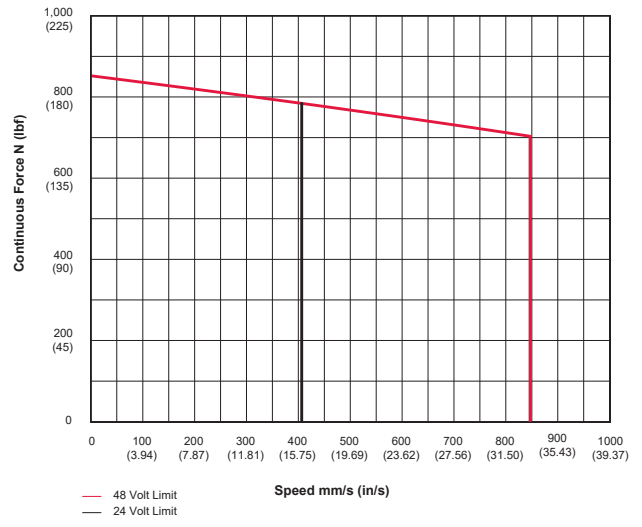

GTX060 - 02
5.08 mm (0.2 in) Screw Lead

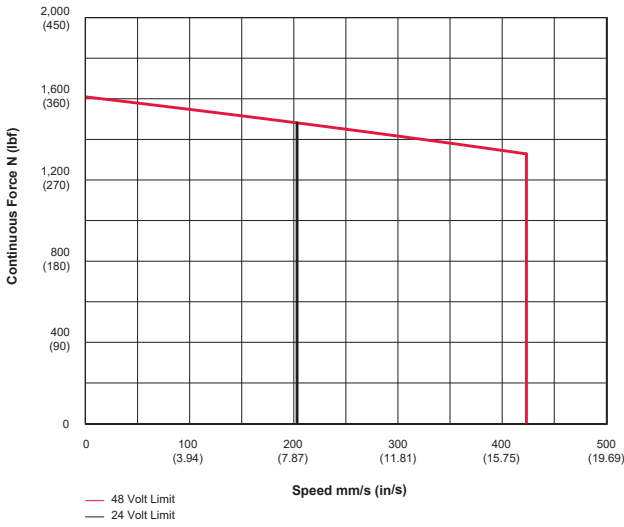

AC Voltage Winding

GTX080 - 01

2.54 mm (0.1 in) Screw Lead

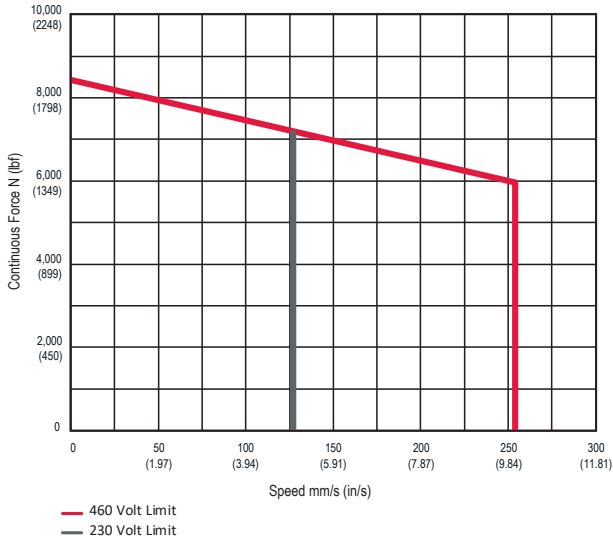

GTX080 - 05

12.7 mm (0.5 in) Screw Lead

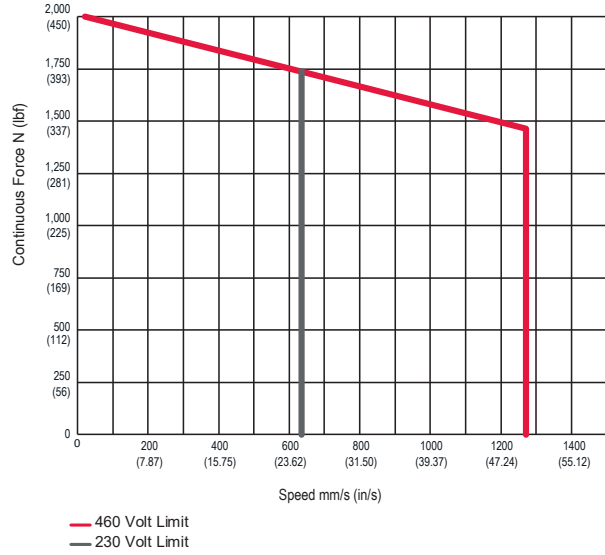

GTX080 - 02

5.08 mm (0.2 in) Screw Lead

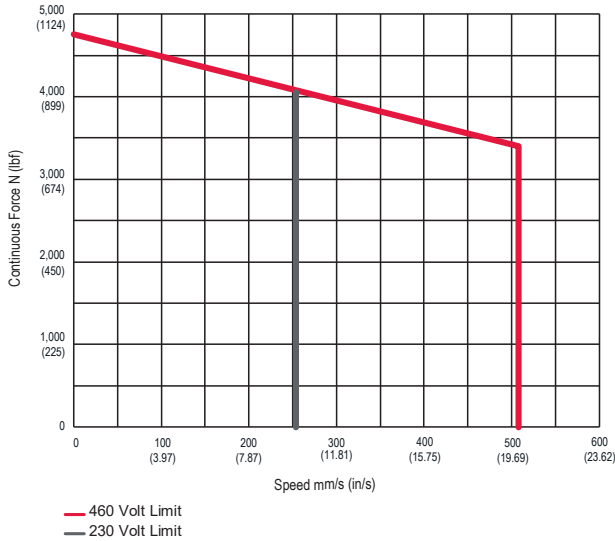

DC Voltage Winding

GTX080 - 01
2.54 mm (0.1 in) Screw Lead

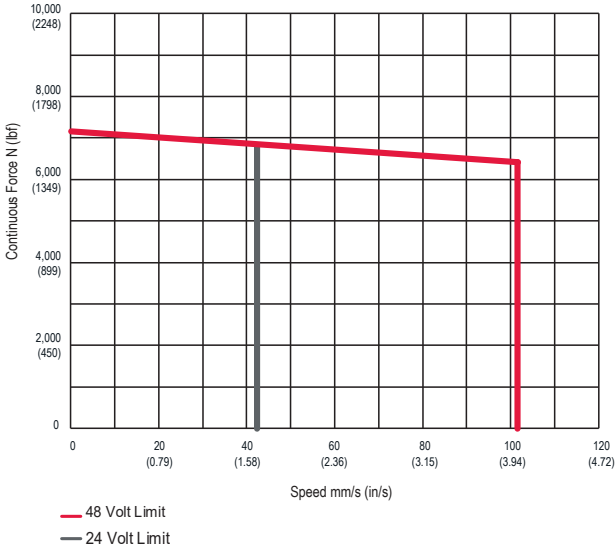

GTX080 0- 05
12.7 mm (0.5 in) Screw Lead

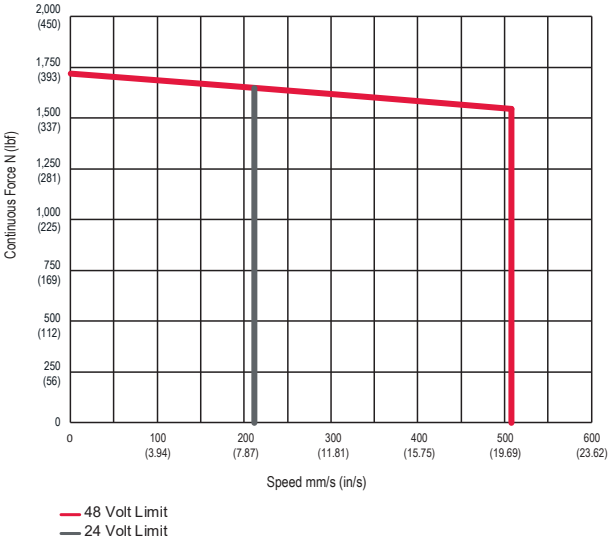

GTX080 - 02
5.08 mm (0.2 in) Screw Lead

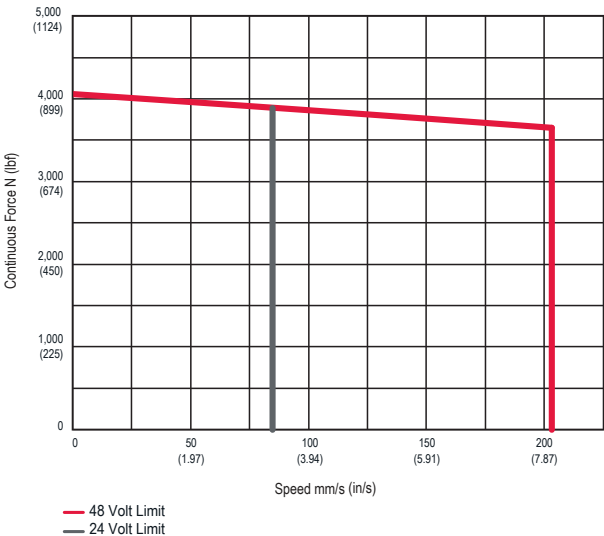

Test data derived using NEMA recommended aluminum heatsink 10" x 10" x 1/4" for GTX080.

AC Voltage Winding

GTX100 - 01

2.54 mm (0.1 in) Screw Lead

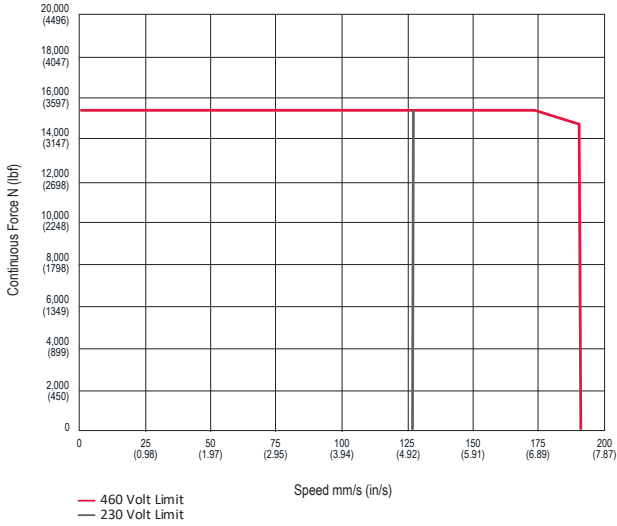

GTX100 - 05

12.7 mm (0.5 in) Screw Lead

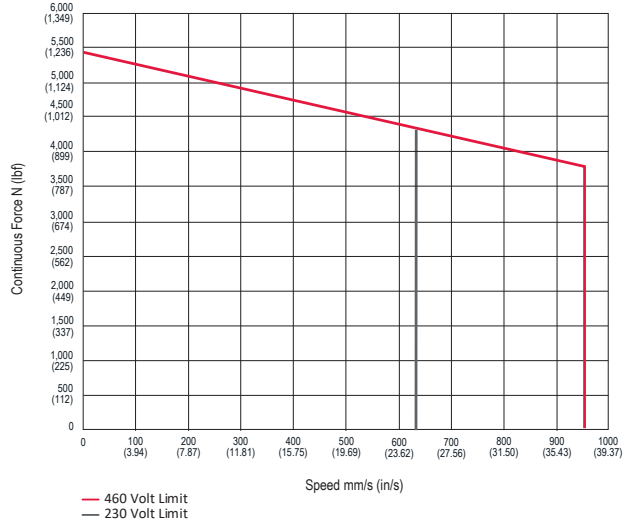

GTX100 - 02

5.08 mm (0.2 in) Screw Lead

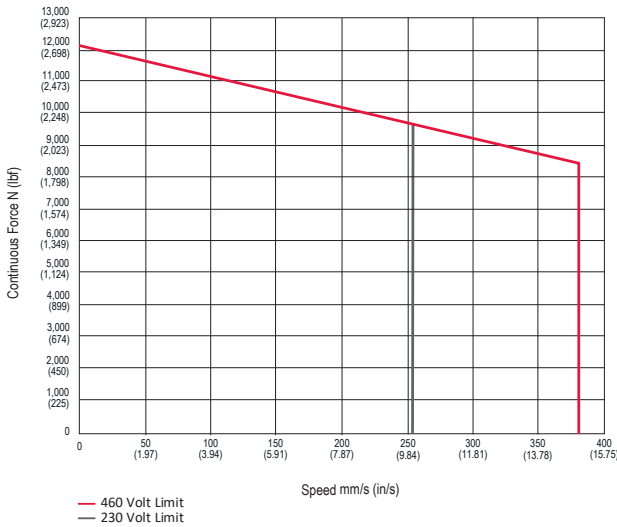

Test data derived using NEMA recommended aluminum heatsink 12" x 12" x 1/2" at 25°C ambient for GTX100.

Options

Motor Winding / Voltage

GTX actuators can be operated at a wide range of voltages (up to 460 Vac). For DC voltage applications, please refer to the order guide "D" callout. Refer to the mechanical/electrical specifications for motor torque and actuator rated force.

4	460 Vac Max
D	48 Vdc Max

Internal Holding Brake

This option provides an internal holding brake for GTX Series actuators. The brake is a permanent magnet brake that is normally engaged. Power must be applied to the brake to disengage the brake.

Feedback Device Options:

Resolvers

Incremental Encoders

Absolute Encoders

Exlar GTX actuators are compatible with a variety of drive platforms available today. Exlar installs, aligns, and wires feedback devices to mimic a typical motor's wiring and cabling commonly used with the listed amplifier manufacturer (see wiring and alignment section for details). If your wiring and alignment is not listed, please consult Exlar.

External Anti-rotate Assembly

The unique design of the GTX Series of linear actuators permits the extending rod to rotate. This capability simplifies setup by allowing the user to rotate the rod in and out of the actuator for mechanical attachment or system testing.

However, this feature also requires that once setup and testing are completed, the rod be kept from rotating so proper linear motion will be maintained. In most applications the actuator's load is coupled to linear bearings, or some other support device. In these cases the load cannot rotate, so an anti-rotation on the actuator is not needed.

Splined Rod Option

The splined rod is an internal anti-rotate option that will restrict rotation but still provide linear motion without the need for an external mechanism. It is not suitable for environments where contaminants may be able to penetrate the actuator. The option does NOT meet the IP66S rating as there is no sealing component where the driven rod extends and retracts. If the unit is installed vertically rod end down there is potential for grease to exit the unit in environments where overheating can occur.

Stainless Steel Rod Options

All thread options on the GTX product line are available in 17-4 stainless steel. This option provides improved corrosion resistance for the main rod of the actuator. This option can be beneficial in applications where the rod could be exposed to harsh chemicals or outdoor environments.

Mounting Options

Both as part of the actuator model code and sold as accessory kits. For applications in which the load is free to rotate, Exlar offers bolt-on anti-rotation systems.

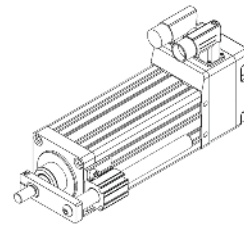

External Limit Switch/ Anti-Rotate Assembly

This option allows external limit switches to be mounted to the GTX Series Actuator. These switches provide travel indication to the controller and are adjustable (Limit switches sold separately).

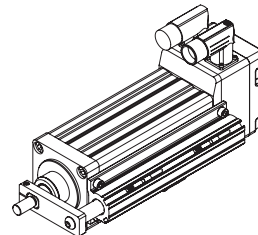

The external limit switch accessory for the GTX Series of linear actuators allows the user to externally mount adjustable switches for use as the end of travel limit switches or home position sensors.

(Limit switches sold separately from actuator)

NOTE: Accessory option "L" required in model mask to order

Switch Type	Exlar Part Number	Turck Part Number
Normally Closed Switch, PNP	43404	BIM-UNT-RP6X
Normally Open Switch, PNP	43403	BIM-UNT-AP6X
Normally Closed Switch, NPN	67635	BIM-UNT-RN6X
Normally Open Switch, NPN	67634	BIM-UNT-AN6X

Dimensions

GTX060 BASE ACTUATOR

ALL DIMENSIONS ARE IN MILLIMETERS

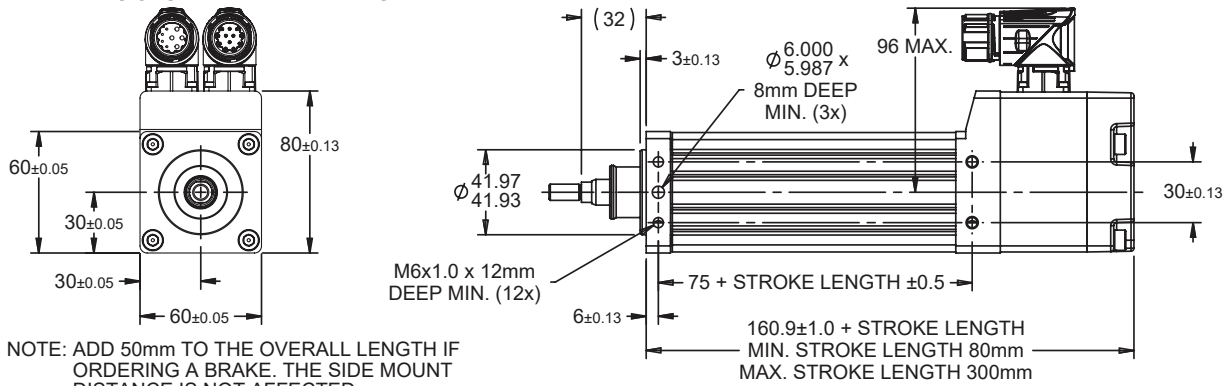

GTX060 WITH SPLINED MAIN ROD

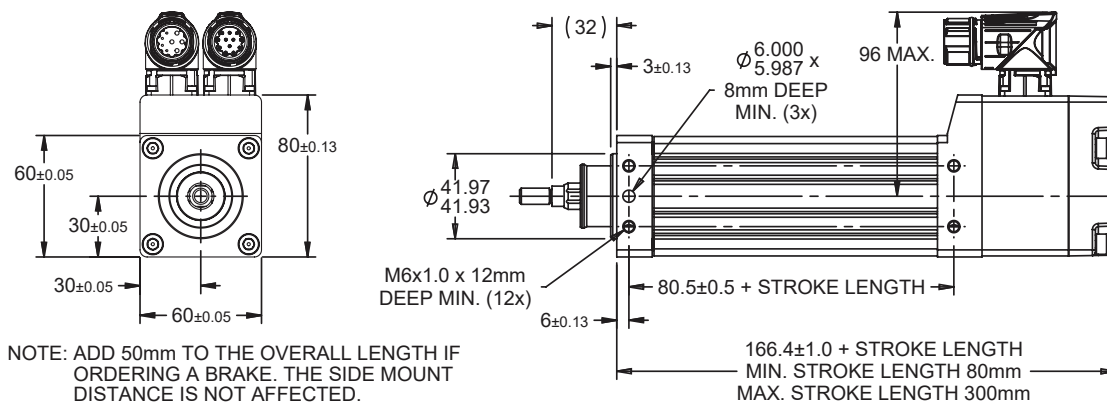

A (ANTI-ROTATE)

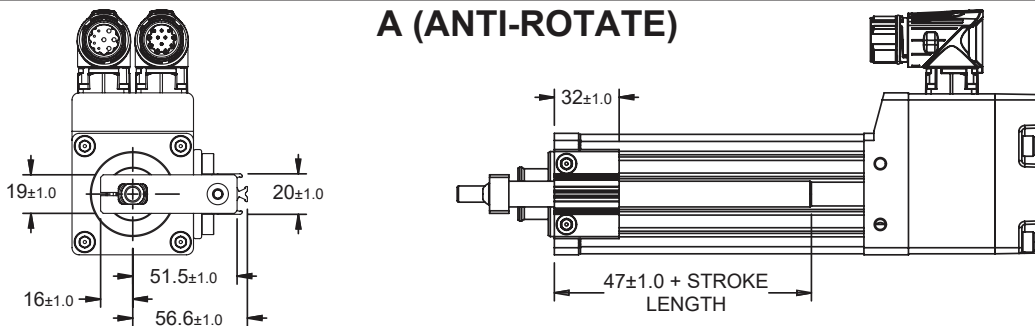

L (Limit Switch Assembly)

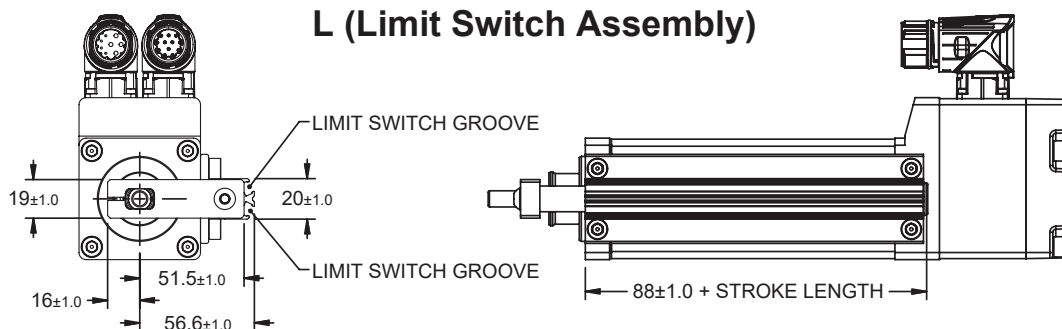

Pre-sale drawings and models are representative and are subject to change. Visit exlar.com to download a 3D model of your desired configuration.

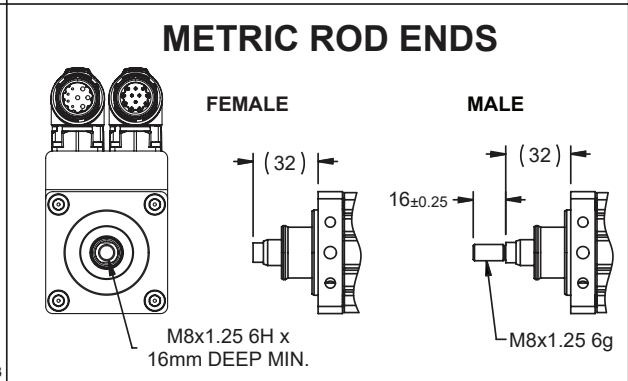
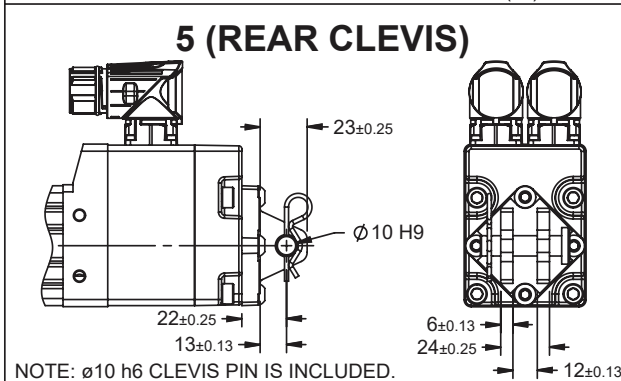
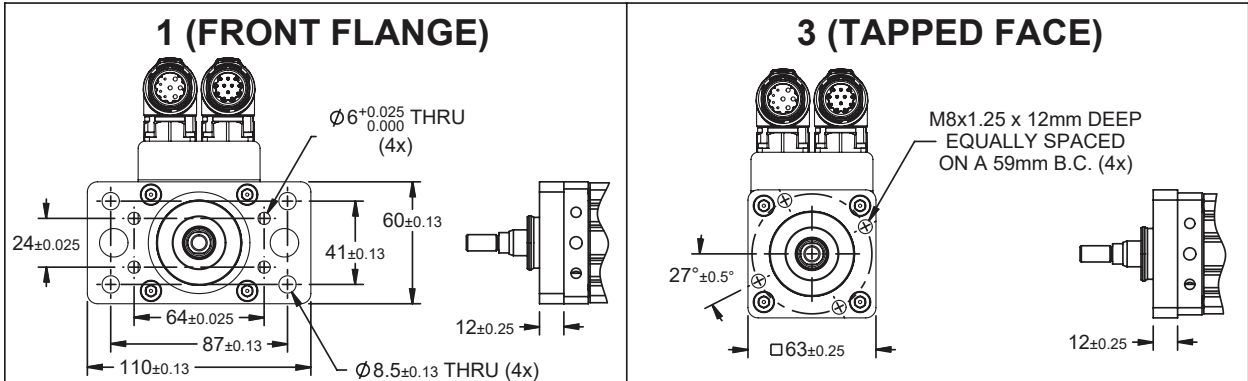

GTX060 ENGLISH OPTIONS

ALL DIMENSIONS ARE IN INCHES

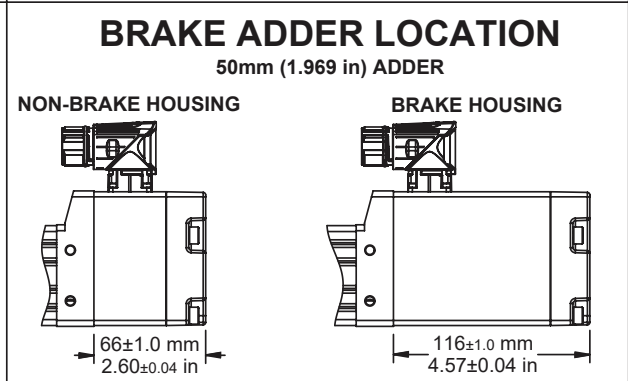
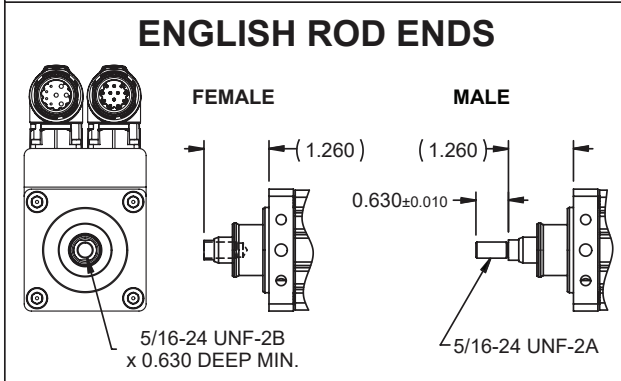
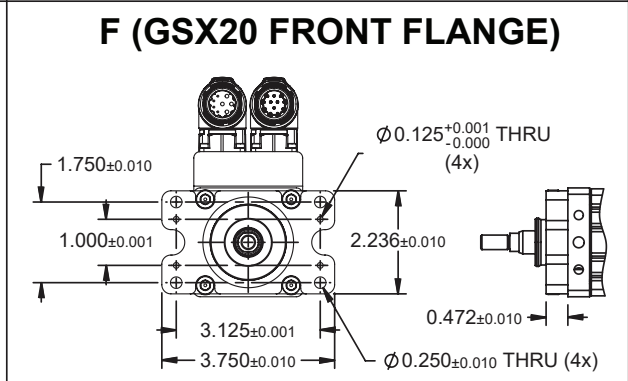
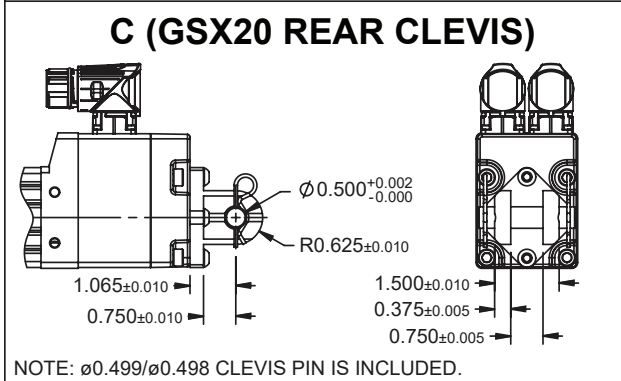

Reference product ordering guide for all available options.

GTX080 BASE ACTUATOR

ALL DIMENSIONS ARE IN MILLIMETERS

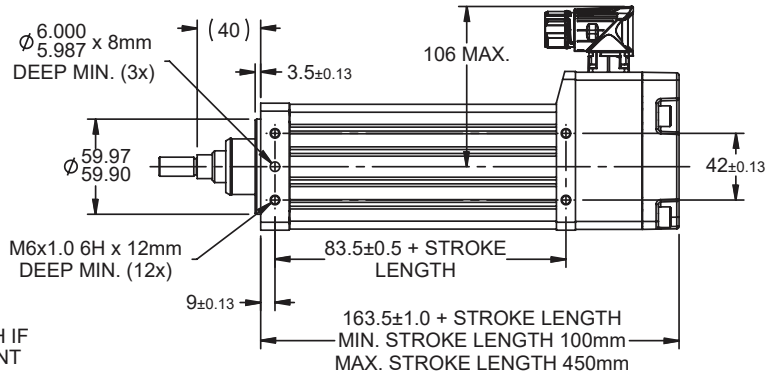
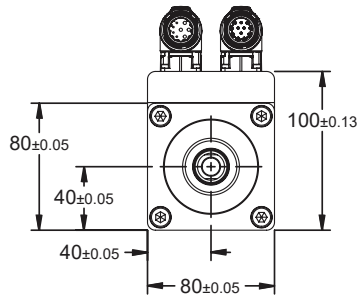

NOTE: ADD 40mm TO THE OVERALL LENGTH IF ORDERING A BRAKE. THE SIDE MOUNT DISTANCE IS NOT AFFECTED.

GTX080 WITH SPLINED MAIN ROD

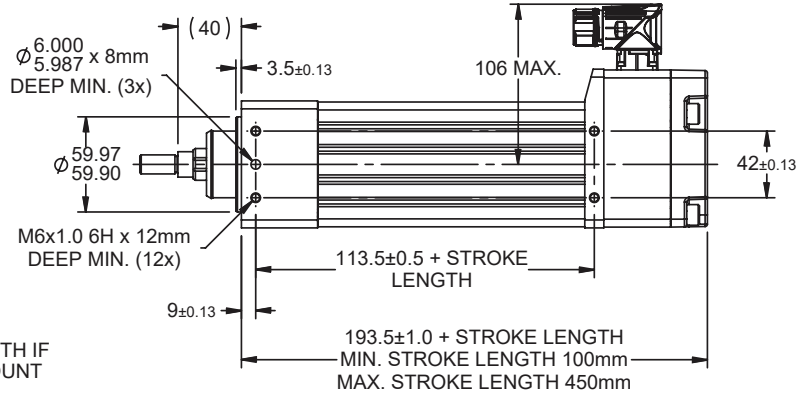
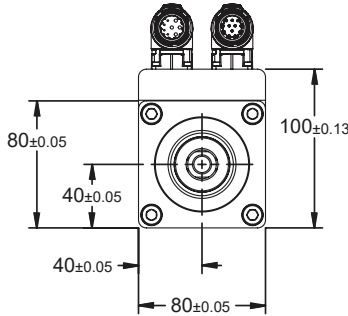

NOTE: ADD 40mm TO THE OVERALL LENGTH IF ORDERING A BRAKE. THE SIDE MOUNT DISTANCE IS NOT AFFECTED.

A (ANTI-ROTATE)

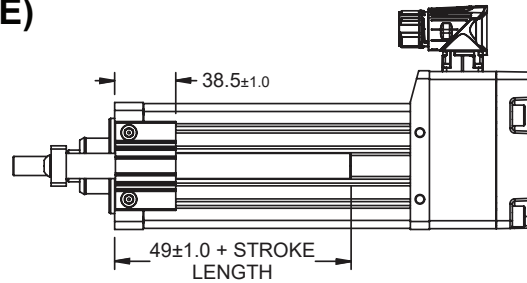
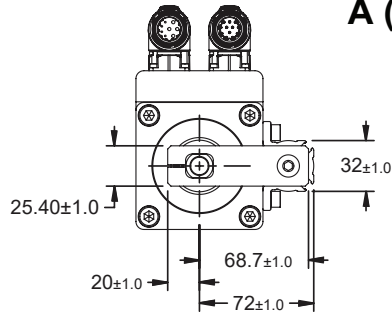

L (LIMIT SWITCH ASSEMBLY)

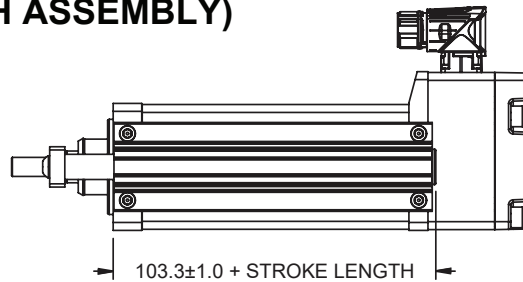
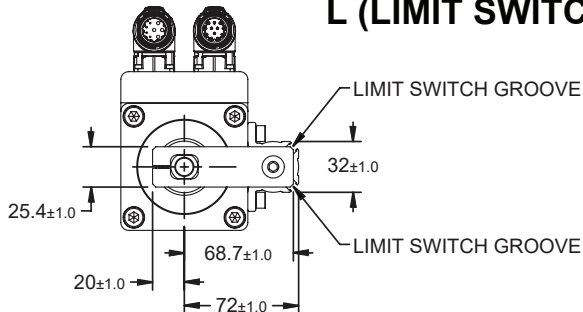

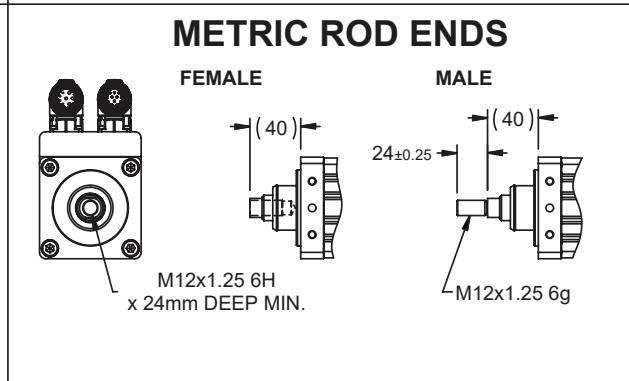
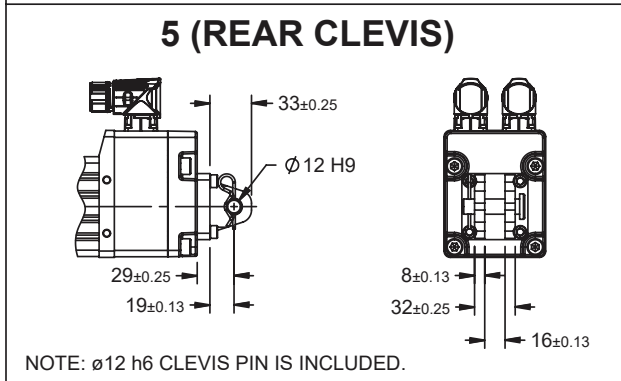
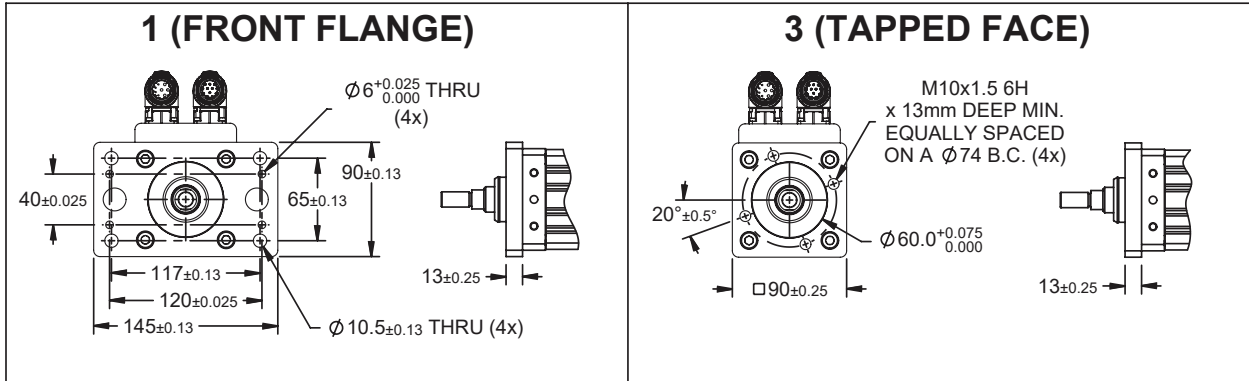

GTX080 ENGLISH OPTIONS

ALL DIMENSIONS ARE IN INCHES

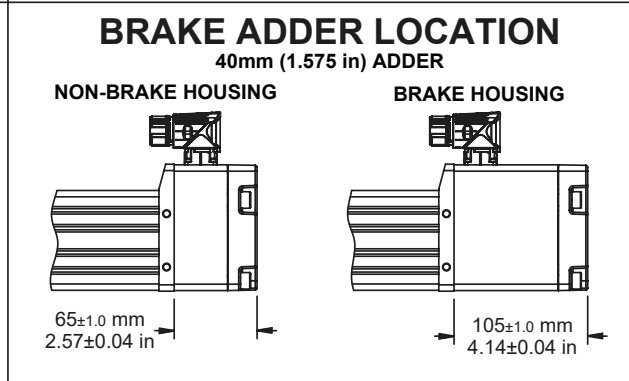
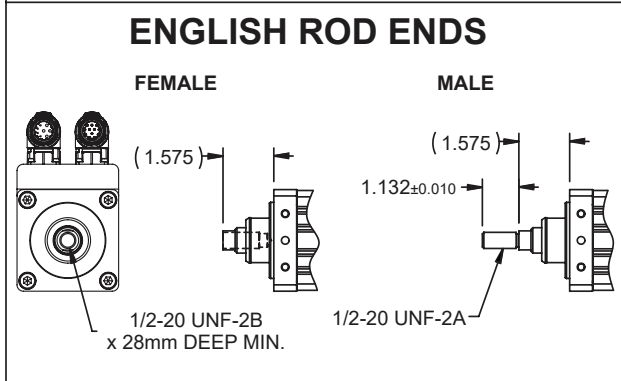
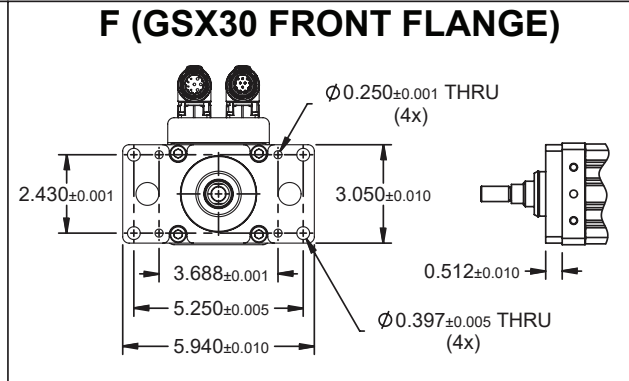
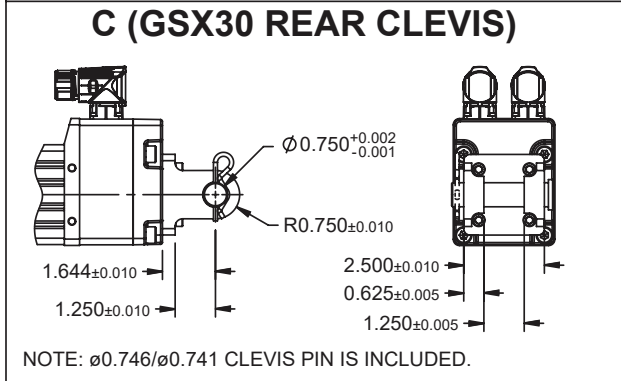

Reference product ordering guide for all available options.

GTX100 BASE ACTUATOR

ALL DIMENSIONS ARE IN MILLIMETERS

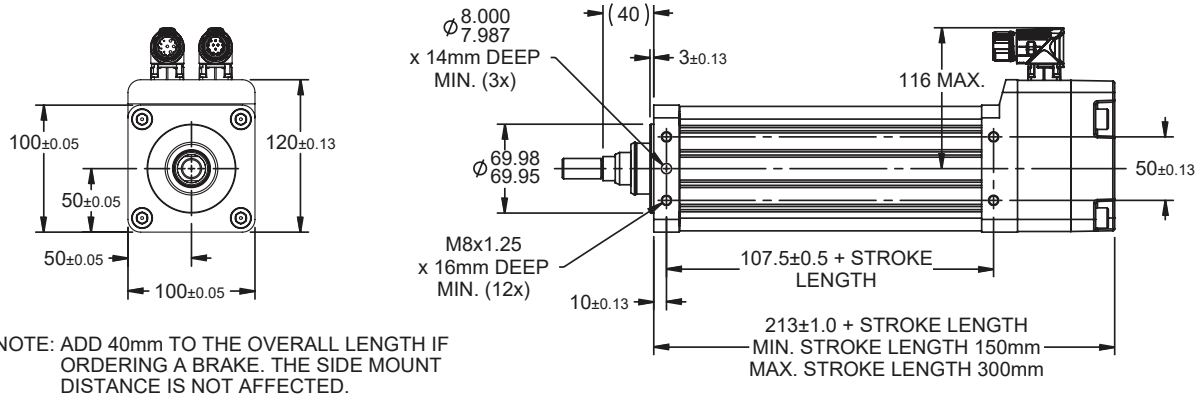

GTX100 WITH SPLINED MAIN ROD

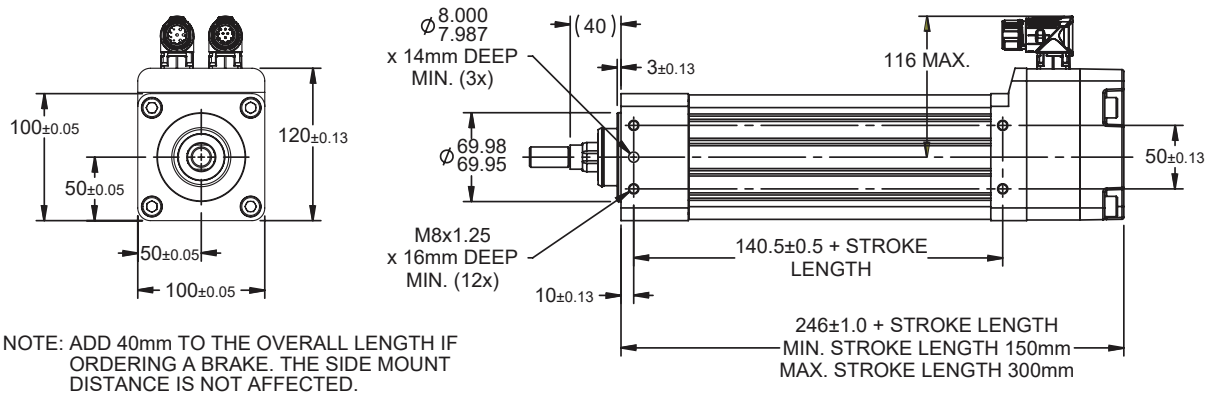

A (ANTI-ROTATE)

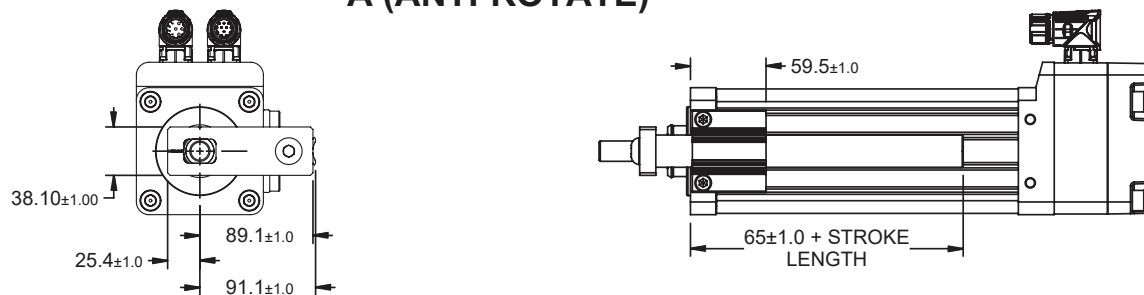

L (LIMIT SWITCH ASSEMBLY)

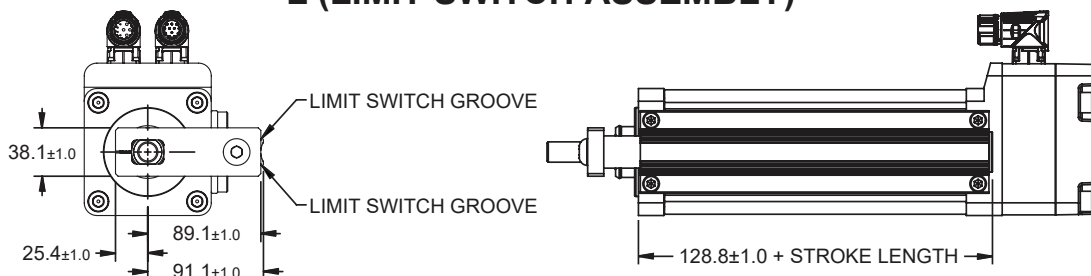

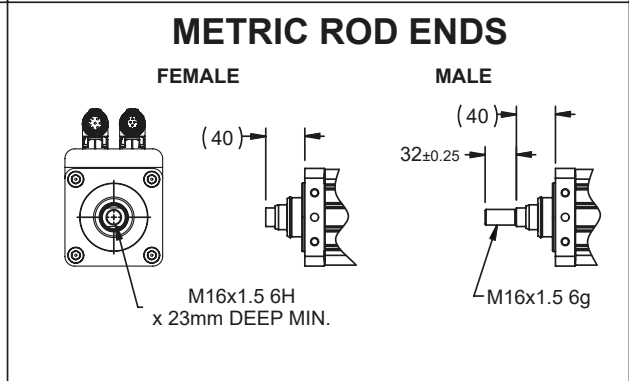
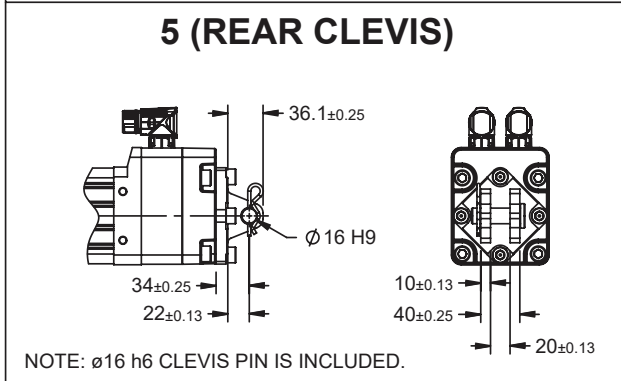
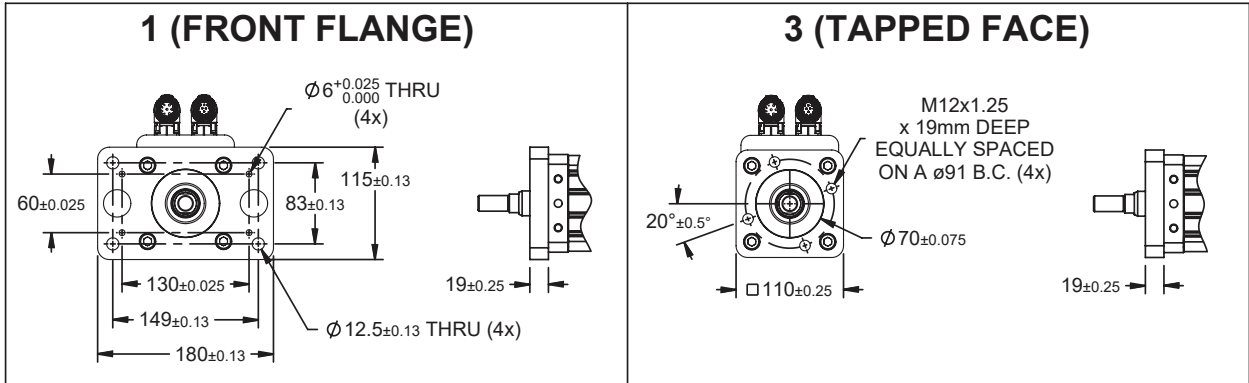

GTX100 ENGLISH OPTIONS

ALL DIMENSIONS ARE IN INCHES

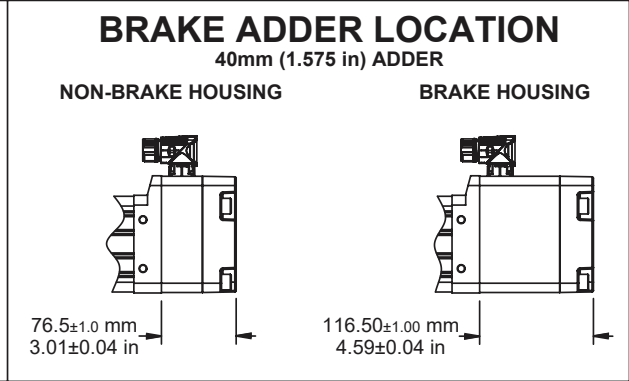
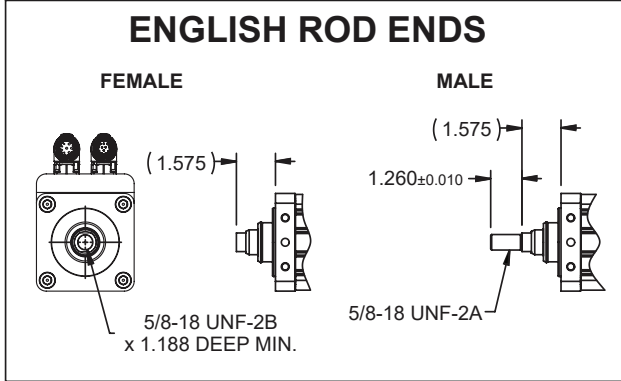
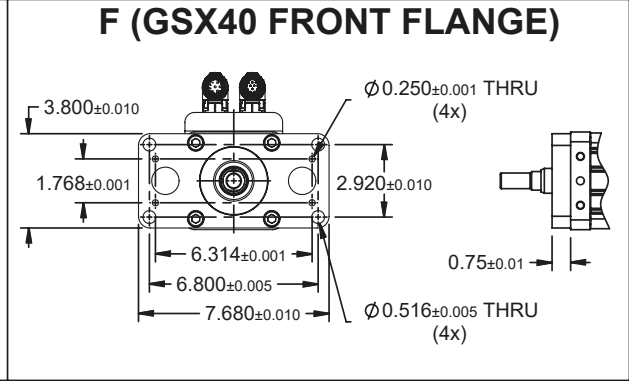
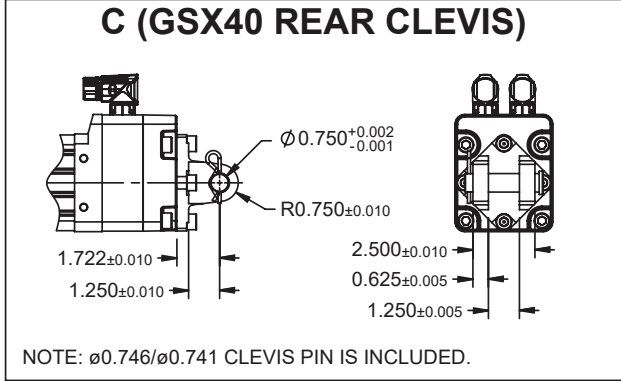

Reference product ordering guide for all available options.

SPHERICAL ROD EYE

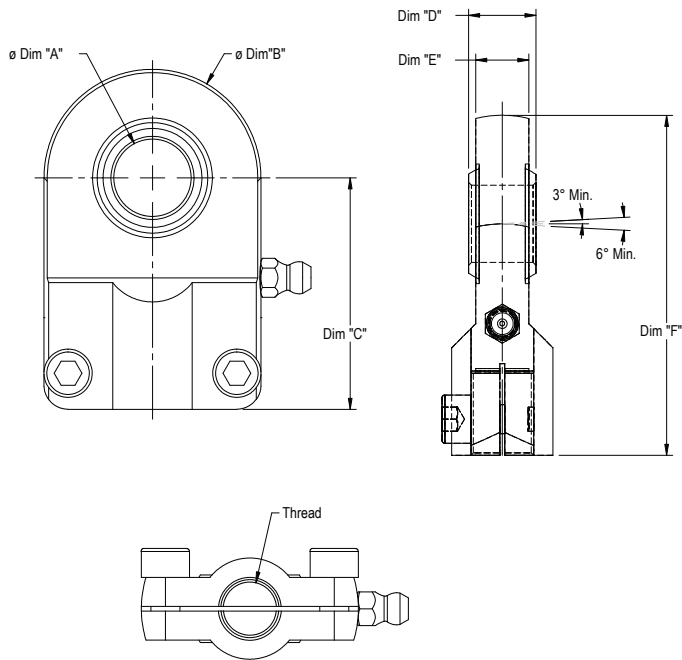

	Dimensional Specs		
	GTX060	GTX080	GTX100
ø Dim "A"	8.065 7.988	16.000 15.992	25.021 25.000
ø Dim "B"	22.25	45.0	65.0
Dim "C"	36.0	48.0	68.0
Dim "D"	12.0	14.0	20.0
Dim "E"	8.0	11.0	17.0
Dim "F"	47.1	70.5	100.5
Thread	M8x1.2	M12x1.25	M16x1.5
Weight (kg)	0.21	0.21	0.66

ROD END CODE "A" IS REQUIRED ON THE ACTUATOR

SPHERICAL ROD EYE ORDER CODE	
GTX060	GTX060-RE1-KIT
GTX080	GTX080-RE1-KIT
GTX100	GTX100-RE1-KIT

ROD CLEVIS

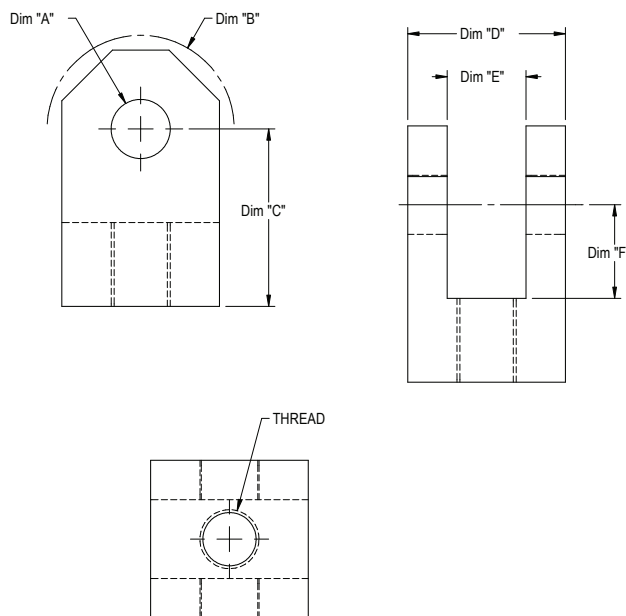

	Dimensional Specs		
	GTX060	GTX080	GTX100
ø Dim "A"	8.065 7.988	12.043 12.000	20.052 20.000
ø Dim "B"	20.0	34.0	58.0
Dim "C"	32.0	36.0	54.0
Dim "D"	16.0	34.0	52.0
Dim "E"	8.0	16.0	30.0
Dim "F"	16.0	19.0	32.0
Thread	M8x1.25	M12x1.25	M16x1.5
Weight (kg)	0.25	0.25	1.0

ROD END CODE "A" IS REQUIRED ON THE ACTUATOR

CLEVIS ROD EYE ORDER CODE	
GTX060	GTX060-RC1-KIT
GTX080	GTX080-RC1-KIT
GTX100	GTX100-RC1-KIT

Pre-sale drawings and models are representative and are subject to change. Visit exlar.com to download a 3D model of your desired configuration.

Feedback Types for GTX

Drive / Feedback Designator Callouts

Drive Manufacturers	Wiring & Alignment Code	Resolver	Incremental Encoder	SICK Hiperface Absolute Encoder	SICK Hiperface DSL Absolute Encoder	Heidenhain Endat 2.2 Absolute Encoder	Heidenhain DRIVE-CliQ Absolute Encoder
AMK	AK	R1A1				H1A1	
B&R Automation	BR	R1A1				H1A2	
Baldor	BD	R1A1				H1A1	
Baumuelller	BM	R1A1		S1A1		H1A2	
Beckhoff Automation	BE					H1A2, H3C2*	
Control Technologies / Nidec	CT	R2B1	E1B2	S1B1		H1B2	
Elau / Schneider	EU			S1A1			
Elmo Motion Control	EL	R1B1	E1B2			H1B2	
Exlar	EX	R1A1	E1A2	S1A2		H1A2	
Infranor	IF	R1B2		S1B2			
Bosch-Rexroth	IN			S2D3		H1D3	
Kollmorgen	KM	R2A1	E1A2			H1A2	
LTI	LS	R2A1		S1A2			
Lenze	LZ	R1B1		S1B1			
Parker	PC	R1B1	E1B2			H1B2	
Rockwell Automation	RA		E1C2	S1C2	S3C0		
Siemens	SM	R1B1				H1B2	H2B5*
Stober Drives	SB	R2A1				H1A1	

*Functional Safety

Feedbacks
R1 – Resolver, 2-pole, 5 kHz, 4 V
R2 – Resolver, 2-pole, 7 kHz, 4.25 V
E1 – Incremental Encoder, 2048 PPR (8192 counts), 8-pole, 5 V, Index Pulse, Hall commutation, 5 Vdc
S1 – SICK Hiperface, SKM36 Multi-turn Absolute Encoder, 18 bit
S2 – SICK Hiperface, SKM36 Multi-turn Absolute Encoder, 18 bit, Rockwell .blb
S3 – SICK Hiperface DSL, EKM36 Multi-turn Absolute Encoder, Rockwell .blb
H1 – Heidenhain EnDat 2.2, EQN 1125 Multi-turn Absolute Encoder, 13 bit
H2 – Heidenhain DRIVE-CliQ, EQN 1135S Multi-turn Absolute Encoder, 23 bit, Functional Safety
H3 – Heidenhain EnDat 2.2, EQN 1135 Multi-turn Absolute Encoder, 23 bit, Functional Safety

Power Connectors	Feedback Connectors
A = 8 pin M23 Size 1, Right Angle Connector	0 = Feedback signal wired through power connector
B = 6 pin M23 Size 1, Right Angle Connector	1 = 12 pin M23 Size 1, P Type, Right Angle Connector
C = 9 pin M23 Size 1, Right Angle Connector	2 = 17 pin M23 Size 1, E Type, Right Angle Connector
D = 4+5 pin M23 size 1, Right Angle Connector	3 = 10 pin M23 Size 1, Right Angle Connector
	5 = 8 pin M12, Straight Connector

Wiring and Alignment Options

AMK-Resolver (AK-R1A1) - Standard Resolver w/M23 connectors

Power Connector Pin-Out		Pin Side View
19819 Connector	Drive Terminology	
1	U	
2	PE	
3	W	
4	V	
A	TH	
B	TH	
C	BR +	
D	BR 0V	

Feedback Connector Pin-Out		Pin Side View
19820 Connector	Drive Terminology	
1	+ Sin	
2	- Sin	
3	+ Cos	
4	- Cos	
5	-	
6	-	
7	-	
8	Shield	
9	+ UREF	
10	- UREF	
11	-	
12	-	
Actuator Case	-	

B & R Automation-Resolver (BR-R1A1) - Standard Resolver w/M23 connectors

Power Connector Pin-Out		Pin Side View
M23 Connector	Drive Terminology	
1	U	
2	PE	
3	W	
4	V	
A	PT1000	
B	PT1000	
C	Brake+	
D	Brake-	

Feedback Connector Pin-Out		Pin Side View
M23 Connector	Drive Terminology	
1	-	
2	-	
3	Cos+	
4	Sin+	
5	Ref+	
6	-	
7	Cos-	
8	Sin-	
9	Ref-	
10	-	
11	-	
12	-	
Actuator Case	-	

Mfg's Cable Part Number- 8CRXXX.12-1

AMK-Heidenhain (AK-H1A1) - EnDat 2.2 Heidenhain EQN1125 multi-turn absolute encoder – ED/EK motor wiring w/M23 connectors

Power Connector Pin-Out		Pin Side View
19819 Connector	Drive Terminology	
1	U	
2	PE	
3	W	
4	V	
A	TH	
B	TH	
C	BR +	
D	BR 0V	

Feedback Connector Pin-Out		Pin Side View
19820 Connector	Drive Terminology	
1	G2N	
2	G2I	
3	G1N	
4	G1I	
5	05P	
6	GND	
7	CLK+	
8	CLK-	
9	DAT+	
10	DAT-	
11	05P	
12	GND	
Actuator Case	-	

B & R Automation-Heidenhain (BR-H1A2) - EnDat 2.2 Heidenhain EQN1125 multi-turn absolute encoder – 8LS/8LM motor wiring w/M23 connectors

Power Connector Pin-Out		Pin Side View
M23 Connector	Drive Terminology	
1	U	
2	PE	
3	W	
4	V	
A	PT1000	
B	PT1000	
C	Brake+	
D	Brake-	

Feedback Connector Pin-Out		Pin Side View
M23 Connector	Drive Terminology	
1	Up Sense	
2	-	
3	-	
4	0V Sense	
5	-	
6	-	
7	Up voltage supply	
8	Clock	
9	Clock-	
10	0V voltage supply	
11	-	
12	B+	
13	B-	
14	Data	
15	A+	
16	A-	
17	Data-	
Actuator Case	-	

Mfg's Cable Part Number- 8CEXXX.12-1

Baldor-Resolver (BD-R1A1) -
Standard Resolver w/M23 connectors

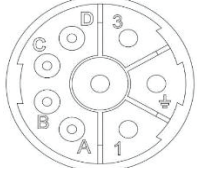
Power Connector Pin-Out		Pin Side View
19819 Connector	Drive Terminology	
1	U	
2	GND	
3	W	
4	V	
A	Therm	
B	Therm	
D	Brake-	

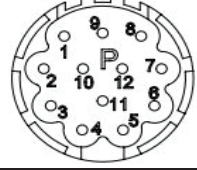
Feedback Connector Pin-Out		Pin Side View
19820 Connector	Drive Terminology	
1	R1 Ref Hi	
2	R2 Ref Lo	
3	S1 Cos+	
4	S3 Cos-	
5	S2 Sin+	
6	S4 Sin-	
7	-	
8	-	
9	-	
10	-	
11	-	
12	-	
Actuator Case	Shield	

Baumuller-Resolver (BM-R1A1) -
Standard Resolver w/M23 connectors

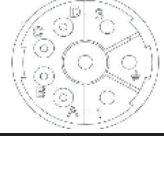
Power Connector Pin-Out		Pin Side View
19819 Connector	Drive Terminology	
1	Phase U	
2	PE	
3	Phase W	
4	Phase V	
A	Brake+	
B	Brake-	
D	-	

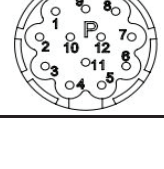
Feedback Connector Pin-Out		Pin Side View
19820 Connector	Drive Terminology	
1	Cos -	
2	-	
3	-	
4	-	
5	Sin -	
6	Sin +	
7	-	
8	Cos +	
9	-	
10	Ref +	
11	-	
12	Ref -	
Actuator Case	Shield	

Baumuller-SICK (BM-S1A1) - SICK Hiperface SKM36
multi-turn absolute encoder – SH motor wiring w/M23 connectors

Baldor-Heidenhain (BD-H1A1) - EnDat 2.2 Heidenhain
EQN1125 multi-turn absolute encoder – ED/EK motor wiring w/M23 connectors

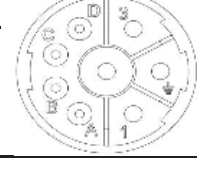
Power Connector Pin-Out		Pin Side View
19819 Connector	Drive Terminology	
1	T1	
2	Earth/Ground	
3	T3	
4	T2	
A	Thermal Switch	
B	Thermal Switch	
D	Brake-	

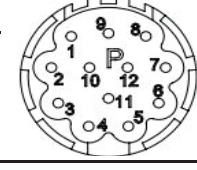
Feedback Connector Pin-Out		Pin Side View
19820 Connector	Drive Terminology	
1	Data-	
2	Sin+	
3	0	
4	Cos+	
5	Clock-	
6	-	
7	Clock+	
8	Cos-	
9	5 volt	
10	DGND	
11	Sin-	
12	Data+	
Actuator Case	-	

Power Connector Pin-Out		Pin Side View
19819 Connector	Drive Terminology	
1	Phase U	
2	PE	
3	Phase V	
4	Phase W	
A	Brake+	
B	Brake-	
D	PT1000	

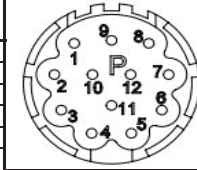
Feedback Connector Pin-Out		Pin Side View
19820 Connector	Drive Terminology	
1	Ref Cos	
2	Daten +	
3	-	
4	-	
5	Sin	
6	Ref Sin	
7	Daten -	
8	Cos	
9	-	
10	GND	
11	-	
12	+V	
Actuator Case	-	

Baumuller-Heidenhain (BM-H1A2) -

EnDat 2.2 Heidenhain EQN1125 multi-turn absolute encoder – 8LS/8LM motor wiring w/M23 connectors

Power Connector Pin-Out		Pin Side View
19819 Connector	Drive Terminology	
1	Phase U	
2	PE	
3	Phase V	
4	Phase W	
A	Brake+	
B	Brake-	
C	-	
D	-	

Feedback Connector Pin-Out		Pin Side View
20494 Connector	Drive Terminology	
1	Up Sense	
2	-	
3	-	
4	0V Sense	
5	PT1000	
6	PT1000	
7	Up voltage supply	
8	Clock	
9	Clock -	
10	0V voltage supply	
11	-	
12	B+	
13	B-	
14	Data	
15	A+	
16	A-	
17	Data -	
Actuator Case	-	

Beckhoff Automation-Heidenhain (BE-H1A2) -

EnDat 2.2 Heidenhain EQN1125 multi-turn absolute encoder – AM3XXXX motor wiring w/M23 connectors

Power Connector Pin-Out		Pin Side View
M23 Connector	Drive Terminology	
1	U	
2	PE	
3	W	
4	V	
A	Brake+	
B	Brake-	
C	PT1000	
D	PT1000	

Feedback Connector Pin-Out		Pin Side View
M23 Connector	Drive Terminology	
1	B-	
2	0V voltage supply	
3	A-	
4	Up voltage supply	
5	Data	
6	-	
7	-	
8	Clock	
9	B+	
10	0V Sense	
11	A+	
12	Up Sense	
13	Data -	
14	-	
15	Clock -	
16	-	
17	-	
Actuator Case	-	

Beckhoff Automation-Heidenhain (BE-H3C2) -

EnDat 2.2 Heidenhain EQN1135 multi-turn absolute encoder – 23 bit, Functional Safety w/M23 connectors

Power Connector Pin-Out		Pin Side View
25967 Connector	Drive Terminology	
A	U	
	V	
C	W	
D	PE	
E	PT1000-	
F	Shield	
G	Brake+	
H	PT1000+	
L	Brake-	

Power cable: ZK4800-8023-xxxx
ZK4800-8024-xxxx

Feedback Connector Pin-Out		Pin Side View
20494 Connector	Drive Terminology	
1	-	
2	GND	
3	-	
4	5 Vdc (±10%)	
5	Data; DX+ Data	
6	Us 11 Vdc	
7	-	
8	Clock; CLK+	
9	-	
10	GND sense	
11	-	
12	5V sense	
13	Data; DX-	
14	-	
15	Clock; CLK-	
16	-	
17	-	
Actuator Case	-	

Feedback Cable: ZK4810-8020-xxxx
ZK4810-8020-xxxx

Control Techniques-Resolver (CT-R2B1) -

Standard Resolver – FM/HD motor wiring w/M23 connectors

Power Connector Pin-Out		Pin Side View
M23 Connector	Drive Terminology	
1	R	
2	S	
¥	GND	
4	T	
5	Brake+	
6	Brake-	

Feedback Connector Pin-Out		Pin Side View
M23 Connector	Drive Terminology	
1	Excitation High	
2	Excitation Low	
3	Cos High	
4	Cos Low	
5	Sin High	
6	Sin Low	
7	Therm Switch	
8	Therm Switch	
9	-	
10	-	
11	-	
12	-	
Actuator Case	Shield	

Mfg's Cable Part Number-
SRBBBBXXXX /
SRBBABXXXX

Control Techniques-Encoder (CT-E1B2) -

Standard Incremental Encoder –
FM/HD motor wiring w/M23 connectors

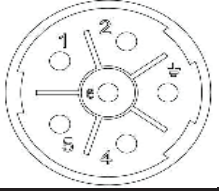
Power Connector Pin-Out		Pin Side View
M23 Connector	Drive Terminology	
1	R	
2	S	
¥	GND	
4	T	
5	Brake+	
6	Brake-	

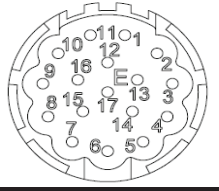
Feedback Connector Pin-Out		Pin Side View
M23 Connector	Drive Terminology	
1	Therm Switch	
2	Therm Switch	
3	-	
4	U	
5	U/	
6	V	
7	V/	
8	W	
9	W/	
10	A	
11	Z	
12	Z/	
13	A/	
14	B	
15	B/	
16	+ 5 VDC	
17	0V	
Actuator Case	-	Mfg's Cable Part Number-S1BAAAXXX

Control Techniques-Heidenhain (CT-H1B2) -

EnDat 2.2 Heidenhain EQN1125 multi-turn absolute encoder Unidrive
M75x w/M23 connectors

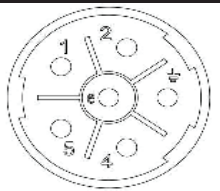
Power Connector Pin-Out		Pin Side View
M23 Connector	Drive Terminology	
1	R	
2	S	
¥	GND	
4	T	
5	Brake+	
6	Brake-	

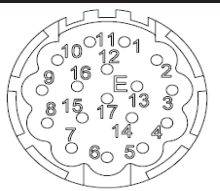
Feedback Connector Pin-Out		Pin Side View
M23 Connector	Drive Terminology	
1	PT1000	
2	PT1000	
3	-	
4	-	
5	-	
6	-	
7	-	
8	Clock +	
9	Clock -	
10	A+	
11	Data +	
12	Data -	
13	A-	
14	B+	
15	B-	
16	+ 5 VDC	
17	COM	
Actuator Case	Shield	

Control Techniques-SICK (CT-S1B1)- SICK Hiperface SKM36 multi-turn absolute encoder – FM/HD motor wiring w/M23 connectors

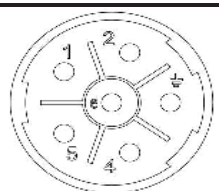
Power Connector Pin-Out		Pin Side View
M23 Connector	Drive Terminology	
1	R	
2	S	
¥	GND	
4	T	
5	Brake+	
6	Brake-	

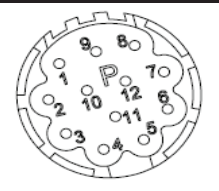
Feedback Connector Pin-Out		Pin Side View
M23 Connector	Drive Terminology	
1	Ref Cos	
2	Daten +	
3	Daten -	
4	Cos	
5	Sin	
6	Ref Sin	
7	Therm Switch	
8	Therm Switch	
9	Screen	
10	Com	
11	-	
12	+V	
Actuator Case	-	Mfg's Cable Part Number-SSBCABXXXX

Elau-SICK (EU-S1A1) - SICK Hiperface SKM36 multi-turn absolute encoder – SH motor wiring w/M23 connectors

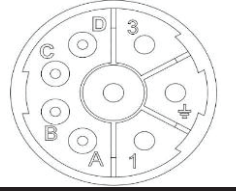
Power Connector Pin-Out		Pin Side View
19819 Connector	Drive Terminology	
1	U (1)	
2	PE	
3	W (3)	
4	V (2)	
A	br+ (8)	
B	br- (7)	
C	PT1000	
D	PT1000	

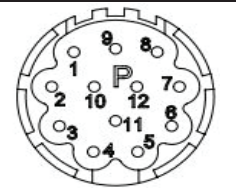
Feedback Connector Pin-Out		Pin Side View
19820 Connector	Drive Terminology	
1	REFCOS	
2	RS485+	
3	-	
4	-	
5	SIN	
6	REFSIN	
7	RS485-	
8	COS	
9	-	
10	GND	
11	-	
12	Us	
Actuator Case	-	Mfg's Cable Part Number-SH Series Absolute Encoder Cable

Elmo-Resolver (EL-R1B1) - Standard Resolver w/M23 connectors

Power Connector Pin-Out		Pin Side View
M23 Connector	Drive Terminology	
1	M1	
2	M3	
⌘	PE	
4	Brake-	
5	M2	
6	Brake+	

Feedback Connector Pin-Out		Pin Side View
M23 Connector	Drive Terminology	
1	-	
2	-	
3	Sin- S4	
4	Cos- S3	
5	Ref R2	
6	-	
7	Sin+ S2	
8	Cos+ S1	
9	Ref R1	
10	-	
11	-	
12	-	
Actuator Case	Shield	

Elmo-Heidenhain (EL-H1B2) - EnDat 2.2 Heidenhain EQN1125 multi-turn absolute encoder w/M23 connectors

Power Connector Pin-Out		Pin Side View
M23 Connector	Drive Terminology	
1	U	
2	W	
⌘	PE	
4	Brake-	
5	V	
6	Brake+	

Feedback Connector Pin-Out		Pin Side View
M23 Connector	Drive Terminology	
1	B-	
2	0V voltage supply	
3	A-	
4	Up voltage supply	
5	Data	
6	-	
7	Therm Switch	
8	Clock	
9	B+	
10	0V Sense	
11	A+	
12	Up Sense	
13	Data -	
14	Therm Switch	
15	Clock -	
16	-	
17	-	
Actuator Case	-	

Elmo-Encoder (EL-E1B2) - Standard Incremental Encoder w/M23 connectors

Power Connector Pin-Out		Pin Side View
M23 Connector	Drive Terminology	
1	M1	
2	M3	
⌘	PE	
4	Brake-	
5	M2	
6	Brake+	

Feedback Connector Pin-Out		Pin Side View
M23 Connector	Drive Terminology	
1	Power Supply 5V	
2	Therm Switch	
3	Power Supply 0V	
4	HC+	
5	HC-	
6	HA+	
7	HA-	
8	HB+	
9	HB-	
10	A+	
11	A-	
12	B+	
13	B-	
14	Z+	
15	Z-	
16	-	
17	Therm Switch	
Actuator Case	-	

Exlar-Resolver (EX-R1A1) - Standard Resolver w/M23 connectors

Power Connector Pin-Out		Pin Side View
M23 Connector	Drive Terminology	
1	R	
2	GND	
3	T	
4	S	
A	Brake+	
B	Brake-	
C	-	
D	-	

AC (4): CBL-PWRB1-SMI-XXX
DC (D): CBL-PWRB2-SMI-XXX

Feedback Connector Pin-Out		Pin Side View
M23 Connector	Drive Terminology	
1	-	
2	Therm Switch	
3	- Cos	
4	- Sin	
5	- Exc	
6	Therm Switch	
7	+ Cos	
8	+ Sin	
9	+ Exc	
10	-	
11	-	
12	-	
Actuator Case	Shield	

CBL-RESOL-SMI-XXX

Exlar-Encoder (EX-E1A2) -
Standard Incremental Encoder 2048 Line w/M23 connectors

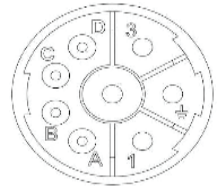
Power Connector Pin-Out		Pin Side View
M23 Connector	Drive Terminology	
1	R	
2	GND	
3	T	
4	S	
A	Brake+	
B	Brake-	
C	-	
D	-	

AC (4): CBL-PWRB1-SMI-XXX
DC (D): CBL-PWRB2-SMI-XXX

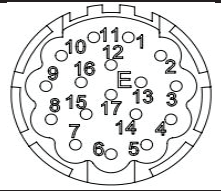
Feedback Connector Pin-Out		Pin Side View
M23 Connector	Drive Terminology	
1	B-	
2	B	
3	A	
4	A-	
5	Z	
6	Z-	
7	GND	
8	Therm Switch	
9	Therm Switch	
10	+5VDC	
11	-	
12	W-	
13	V-	
14	U-	
15	W	
16	V	
17	U	
Actuator Case	-	

CBL-ENCOD-SMI-XXX

Exlar-Heidenhain (EX-H1A2) - EnDat 2.2 Heidenhain
EQN1125 multi-turn absolute encoder w/M23 connectors

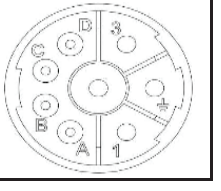
Power Connector Pin-Out		Pin Side View
M23 Connector	Drive Terminology	
1	U	
2	PE	
3	W	
4	V	
A	Brake+	
B	Brake-	
C	-	
D	-	

AC (4): CBL-PWRB1-SMI-XXX
DC (D): CBL-PWRB2-SMI-XXX

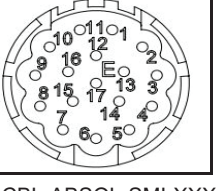
Feedback Connector Pin-Out		Pin Side View
M23 Connector	Drive Terminology	
1	B-	
2	0V voltage supply	
3	A-	
4	Up voltage supply	
5	Data+	
6	-	
7	Therm Switch	
8	Clock	
9	B	
10	0V Sense	
11	A	
12	Up Sense	
13	Data -	
14	Therm Switch	
15	Clock -	
16	-	
17	-	
Actuator Case	-	

CBL-ABSOL-SMI-XXX

Exlar-SICK (EX-S1A2) - SICK Hiperface SKM36 multi-turn
absolute encoder w/M23 connectors

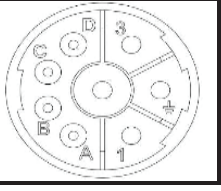
Power Connector Pin-Out		Pin Side View
M23 Connector	Drive Terminology	
1	R	
2	GND	
3	T	
4	S	
A	Brake+	
B	Brake-	
C	-	
D	-	

AC (4): CBL-PWRB1-SMI-XXX
DC (D): CBL-PWRB2-SMI-XXX

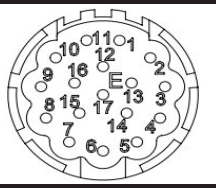
Feedback Connector Pin-Out		Pin Side View
M23 Connector	Drive Terminology	
1	Sin +	
2	Com	
3	Cos +	
4	+5V	
5	Ref +	
6	-	
7	Therm Switch	
8	-	
9	Sin -	
10	-	
11	Cos -	
12	-	
13	Ref -	
14	Therm Switch	
15	-	
16	-	
17	-	
Actuator Case	-	

CBL-ABSOL-SMI-XXX

Infranor-Resolver (IF-R1B2) - Standard Resolver w/M23
connectors

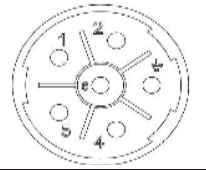
Power Connector Pin-Out		Pin Side View
20453 Connector	Drive Terminology	
1	R	
2	S	
3	GND	
4	T	
5	Brake+	
6	Brake-	

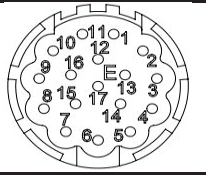
Feedback Connector Pin-Out		Pin Side View
20494 Connector	Drive Terminology	
1	S2	
2	S4	
3	S3	
4	S1	
5	R1	
6	R2	
7	-	
8	-	
9	-	
10	-	
11	-	
12	Therm	
13	Therm	
14	-	
15	-	
16	-	
17	-	
Actuator Case	-	

Infranor-SICK (IF-S1B2) - SICK Hiperface SKM36 multi-turn absolute encoder w/M23 connectors

Power Connector Pin-Out		Pin Side View
20453 Connector	Drive Terminology	
1	R	
2	S	
3	GND	
4	T	
5	Brake+	
6	Brake-	

Feedback Connector Pin-Out		Pin Side View
20494 Connector	Drive Terminology	
1	Sin +	
2	Sin -	
3	Cos +	
4	Cos -	
5	Ref +	
6	Ref -	
7	-	
8	-	
9	-	
10	Com	
11	+ 5V	
12	PT1000	
13	PT1000	
14	-	
15	-	
16	-	
17	0	
Actuator Case	-	

Bosch-Rexroth-Heidenhain (IN-H1D3)- EnDat Heidenhain EQN1125 multi-turn absolute Indradrive wiring w/M23 connectors

Power Connector Pin-Out		Pin Side View
M23 Connector	Drive Terminology	
U1	Phase U	
V1	Phase V	
W1	Phase W	
PE	Earth	
5	PT1000	
6	PT1000	
7	Brake+	
8	Brake-	
9	-	

Feedback Connector Pin-Out		Pin Side View
M23 Connector	Drive Terminology	
1	Vcc_Encoder	
2	GND_Encoder	
3	A+	
4	A-	
5	B+	
6	B-	
7	Data +	
8	Data -	
9	Clock	
10	Clock -	

Bosch-Rexroth-SICK (IN-S2D3)- SICK Hiperface multi-turn absolute encoder – MSK motor wiring w/M23 connectors

Power Connector Pin-Out		Pin Side View
M23 Connector	Drive Terminology	
U1	Phase U	
V1	Phase V	
W1	Phase W	
PE	Earth	
5	PT1000	
6	PT1000	
7	Brake+	
8	Brake-	
9	-	

Feedback Connector Pin-Out		Pin Side View
M23 Connector	Drive Terminology	
1	Vcc_Encoder	
2	GND_Encoder	
3	A+	
4	A-	
5	B+	
6	B-	
7	EncData+	
8	EncData-	
9	-	
10	-	

Mfg's Cable Part Number- RKG4200

Kollmorgen-Resolver (KM-R2A1) - Standard Resolver – AKM motor wiring w/M23 connectors

Power Connector Pin-Out		Pin Side View
M23 Connector	Drive Terminology	
1	U	
2	GND	
3	W	
4	V	
A	Brake+	
B	Brake-	
C	-	
D	-	

Feedback Connector Pin-Out		Pin Side View
M23 Connector	Drive Terminology	
1	-	
2	Therm Switch	
3	Cos Lo (S4)	
4	Sin Lo (S3)	
5	Ref Lo (R2)	
6	Therm Switch	
7	Cos Hi (S2)	
8	Sin Hi (S1)	
9	Ref Hi (R1)	
10	-	
11	-	
12	-	
Actuator Case	Shield	

Mfg's Cable Part Number- VF-RA2474N-XX

Kollmorgen-Encoder (KM-E1A2) -
Standard Incremental Encoder – AKM motor wiring w/ M23 connectors

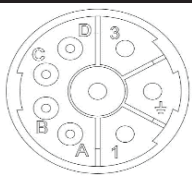
Power Connector Pin-Out		Pin Side View
M23 Connector	Drive Terminology	
1	U	
2	PE	
3	W	
4	V	
A	Brake+	
B	Brake-	
C	-	
D	-	

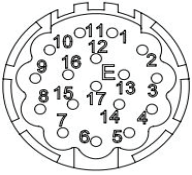
Feedback Connector Pin-Out		Pin Side View
M23 Connector	Drive Terminology	
1	B+	
2	B-	
3	A+	
4	A-	
5	Z	
6	Z-	
7	GND	
8	Therm Switch	
9	Therm Switch	
10	Vcc	
11	-	
12	U-	
13	V-	
14	W-	
15	U	
16	V	
17	W	
Actuator Case	-	

Mfg's Cable Part Number-
CF-CB7374N-XX

LTI-SICK (LS-S1A2) - SICK Hiperface SKM36 multi-turn absolute encoder w/M23 connectors

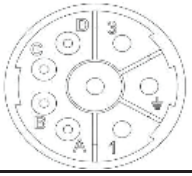
Power Connector Pin-Out		Pin Side View
19819 Connector	Drive Terminology	
1	Phase U	
2	Protective Earth	
3	Phase W	
4	Phase V	
A	Brake+	
B	Brake-	
C	PT1000	
D	PT1000	

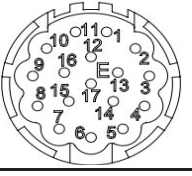
Feedback Connector Pin-Out		Pin Side View
20494 Connector	Drive Terminology	
1	COS+	
2	REFCOS	
3	SIN+	
4	REFSIN	
5	-	
6	-	
7	GND	
8	-	
9	Us 7-12v	
10	Dataen+ RS485	
11	Dataen- RS485	
12	-	
13	-	
14	-	
15	-	
16	-	
17	-	
Actuator Case	-	

LTI-Resolver (LS-R2A1) - Standard Resolver – AKM motor wiring w/M23 connectors

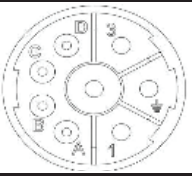
Power Connector Pin-Out		Pin Side View
19819 Connector	Drive Terminology	
1	U	
2	GND	
3	W	
4	V	
A	Brake+	
B	Brake-	
C	-	
D	-	

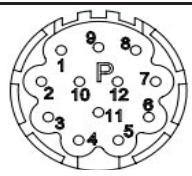
Feedback Connector Pin-Out		Pin Side View
19820 Connector	Drive Terminology	
1	(S1) Cos +	
2	(S3) Cos -	
3	(S2) Sin +	
4	(S4) Sin -	
5	-	
6	(R1) Ref +	
7	(R2) Ref -	
8	-	
9	-	
10	-	
11	PT1000+	
12	PT1000-	
Actuator Case	-	

Lenze-Resolver (LZ-R1B1) - Standard Resolver – MCS motor wiring w/M23 connectors

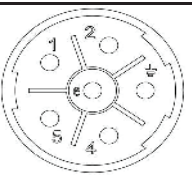
Power Connector Pin-Out		Pin Side View
M23 Connector	Drive Terminology	
1	Y1 / BD1	
2	Y2 / BD2	
3	PI	
4	U	
5	V	
6	W	

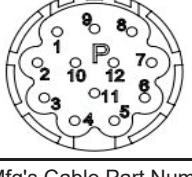
Feedback Connector Pin-Out		Pin Side View
M23 Connector	Drive Terminology	
1	+ Ref	
2	- Ref	
3	-	
4	+ Cos	
5	- Cos	
6	+ Sin	
7	- Sin	
8	-	
9	-	
10	-	
11	PT1000	
12	PT1000	
Actuator Case	-	

Mfg's Cable Part Number-
MCS Series Resolver Cable

Lenze-Encoder (LZ-S1B1) - SICK Hiperface SKM36 multi-turn absolute encoder w/M23 connectors

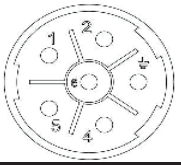
Power Connector Pin-Out		Pin Side View
M23 Connector	Drive Terminology	
1	Y1 / BD1	
2	Y2 / BD2	
¥	PI	
4	U	
5	V	
6	W	

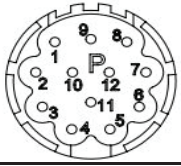
Feedback Connector Pin-Out		Pin Side View
M23 Connector	Drive Terminology	
1	+ SIN	
2	- COS	
3	+ COS	
4	+ 8 V	
5	Mass	
6	- RS485	
7	+ RS485	
8	-	
9	- SIN	
10	-	
11	PT1000	
12	PT1000	

Mfg's Cable Part Number-
MCS Series Absolute Encoder Cable

Actuator Case	-
---------------	---

Parker-Encoder (PC-E1B2) - Standard Incremental Encoder – MPP series motor wiring w/M23 connectors

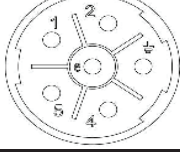
Power Connector Pin-Out		Pin Side View
M23 Connector	Drive Terminology	
1	U	
2	W	
¥	PE	
4	Brake+	
5	Brake-	
6	V	

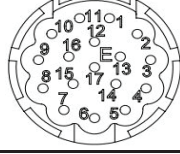
Feedback Connector Pin-Out		Pin Side View
M23 Connector	Drive Terminology	
1	A-	
2	A+	
3	-	
4	Hall 1	
5	Hall 3	
6	Hall 2	
7	Ground	
8	+5 vdc	
9	Therm Switch	
10	-	
11	B	
12	B -	
13	Therm Switch	
14	-	
15	Z+	
16	Z-	
17	-	

Mfg's Cable Part Number-
SMH Series Resolver Cable

Actuator Case	-
---------------	---

Parker-Resolver (PC-R1B1) - Standard Resolver – SMH motor wiring w/M23 connectors

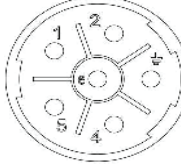
Power Connector Pin-Out		Pin Side View
M23 Connector	Drive Terminology	
1	U	
2	V	
¥	PE	
4	Brake+	
5	Brake-	
6	W	

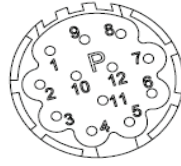
Feedback Connector Pin-Out		Pin Side View
M23 Connector	Drive Terminology	
1	Sin -	
2	Sin +	
3	-	
4	-	
5	-	
6	-	
7	Ref -	
8	PT1000	
9	PT1000	
10	Ref +	
11	Cos +	
12	Cos -	

Mfg's Cable Part Number-
SMH Series Incremental Encoder Cable

Actuator Case	Shield
---------------	--------

Parker-Heidenhain (PC-H1B2) - EnDat 2.2 Heidenhain EQN1125 multi-turn absolute encoder w/M23 connectors

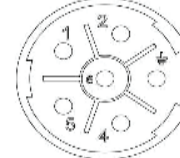
Power Connector Pin-Out		Pin Side View
20453 Connector	Drive Terminology	
1	U	
2	V	
¥	GND	
4	Brake+	
5	Brake-	
6	W	

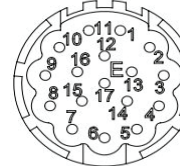
Feedback Connector Pin-Out		Pin Side View
20494 Connector	Drive Terminology	
1	CH A-	
2	CH A+	
3	-	
4	CLK +	
5	CLK -	
6	-	
7	Ground	
8	Vcc	
9	Therm	
10	-	
11	CH B+	
12	CH B-	
13	Therm	
14	Up	
15	Data +	
16	Data -	
17	-	

Actuator Case	-
---------------	---

Rockwell Automation-Encoder (RA-E1C2) -
Standard Incremental Encoder - MPL Type M feedback w/M23 connectors

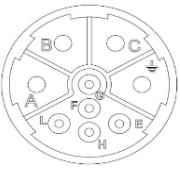
Power Connector Pin-Out		Pin Side View
M23 Connector	Drive Terminology	
A	Phase U	
B	Phase V	
C	Phase W	
D	Ground	
E	-	
F	Brake+	
G	Brake-	
H	-	
L	-	

See Below*

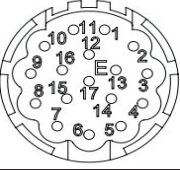
Feedback Connector Pin-Out		Pin Side View
M23 Connector	Drive Terminology	
1	A(+)	
2	A(-)	
3	B(+)	
4	B(-)	
5	I(+)	
6	I(-)	
7	-	
8	-	
9	EPWR_5V	
10	Common	
11	-	
12	-	
13	Therm Switch	
14	Therm Switch	
15	S1	
16	S2	
17	S3	
Actuator Case	-	

Mfg's Cable Part Number-
2090-CFBM7DF-CDAxyy

*GTX060 & GTX080:
2090-CPBM7DF-16Axyy
GTX100: 2090-CPBM7DF-
14Axyy

Rockwell Automation-SICK (RA-S1C2) -
Hiperface, SKM36 multi-turn absolute encoder. MPL Type V feedback
(128 sin/cos) /M23 connectors¹

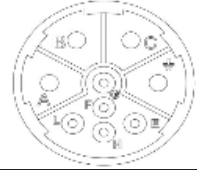
Power Connector Pin-Out		Pin Side View
M23 Connector	Drive Terminology	
A	Phase U	
B	Phase V	
C	Phase W	
D	Ground	
E	-	
F	Brake+	
G	Brake-	
H	-	
L	-	

See Below*

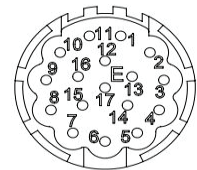
Feedback Connector Pin-Out		Pin Side View
M23 Connector	Drive Terminology	
1	Sine +	
2	Sine -	
3	Cos +	
4	Cos -	
5	Data +	
6	Data -	
7	-	
8	-	
9	-	
10	ECOM	
11	+9 vdc	
12	-	
13	Therm Switch	
14	Therm Switch	
15	-	
16	-	
17	-	
Actuator Case	-	

Mfg's Cable Part Number-
2090-CFBM7DF-CDAxyy

1. Not compatible with Kinetix
300 Drives.

*GTX060 & GTX080:
2090-CPBM7DF-16Axyy
GTX100: 2090-CPBM7DF-
14Axyy

**Rockwell Automation-SICK Absolute DSL
Encoder (RA-S3C0) -** Hiperface, EKM36 multi-turn absolute
encoder w/M23 connectors

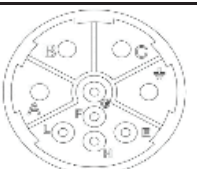
Power Connector Pin-Out		Pin Side View
M23 Connector	Drive Terminology	
A	Phase U	
B	Phase V	
C	Phase W	
D	Ground	
E	Data +	
F	Brake+	
G	Brake-	
H	Data -	
L	-	

Mfg's Cable Part Number-
2090-CSBM1DE-14AA05

Siemens-Resolver (SM-R1B1) - Standard Resolver –
1FK7 motor wiring w/M23 connectors

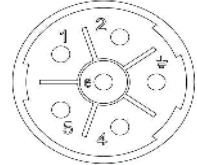
Power Connector Pin-Out		Pin Side View
M23 Connector	Drive Terminology	
1	U	
2	V	
3	GNYE	
4	BD1+	
5	BD2-	
6	W	

See Below*

Feedback Connector Pin-Out		Pin Side View
M23 Connector	Drive Terminology	
1	SIN	
2	*SIN	
3	-	
4	-	
5	-	
6	Shield	
7	-Vpp	
8	PT1000	
9	PT1000	
10	+Vpp	
11	COS	
12	*COS	
Actuator Case	Shield	

Mfg's Cable Part Number-
6FX5002-2CF02-...

*GTX060 & GTX080:
6FX5002-5DA01-...
GTX100: 6FX5002-5DA11-....

Siemens-Heidenhain (SM-H2B5) - EnDat 2.2

Heidenhain DRIVE-CliQ, EQN 1135S Multi-turn Absolute Encoder, 23 bit, Functional Safety w/M23 connectors

Power Connector Pin-Out		Pin Side View
20453 Connector	Drive Terminology	
1	U	
	V	
¥	GNYE	
4	BD1+	
5	BD2-	
6	W	

Mfgs Cable Part Number - 6FX5002-5DA01-...

Feedback Connector Pin-Out		Pin Side View
78262 Connector	Drive Terminology	
1	UP	
2	NA	
3	RXP	
4	RXN	
5	0V	
6	TXN	
7	TXP	
8	NA	

Mfgs Cable Part Number - 6FX.002-2DC36-...

Siemens-Heidenhain (SM-H1B2) - EnDat 2.2

Heidenhain EQN1125 multi-turn absolute encoder – 1FK7 motor wiring w/M23 connectors

Power Connector Pin-Out		Pin Side View
M23 Connector	Drive Terminology	
1	U	
2	V	
¥	GNYE	
4	BD1+	
5	BD2-	
6	W	

See Below*

Feedback Connector Pin-Out		Pin Side View
M23 Connector	Drive Terminology	
1	A+	
2	A-	
3	+ data	
4	-	
5	+clock	
6	-	
7	M-Encoder	
8	PT1000	
9	PT1000	
10	P-Encoder	
11	B+	
12	B-	
13	- data	
14	-clock	
15	0 V Sense	
16	5 V Sense	
17	-	
Actuator Case	-	

Mfg's Cable Part Number- 6FX.002-2DC36-....

*GTX060 & GTX080:
6FX5002-5DA01-...
GTX100: 6FX5002-5DA11-....

Stober-Resolver (SB-R2A1) - Standard Resolver ED/EK

motor wiring w/M23 connector

Power Connector Pin-Out		Pin Side View
19819 Connector	Drive Terminology	
1	U	
2	GND	
3	V	
4	W	
A	Brake	
B	Brake	
C	Therm Switch	
D	Therm Switch	

Feedback Connector Pin-Out		Pin Side View
19820 Connector	Drive Terminology	
1	Sin + (S4)	
2	Sin - (S2)	
3	Cos + (S3)	
4	Cos - (S1)	
5	-	
6	-	
7	Erreg+ (R2)	
8	Erreg- (R1)	
9	-	
10	-	
11	-	
12	-	
Actuator Case	-	

Stober-Heidenhain (SB-H1A1) - EnDat 2.2 Heidenhain

EQN1125 multi-turn absolute encoder – ED/EK motor wiring w/M23 connectors

Power Connector Pin-Out		Pin Side View
19819 Connector	Drive Terminology	
1	U	
2	GND	
3	S	
4	T	
A	Brake	
B	Brake	
C	Therm Switch	
D	Therm Switch	

Feedback Connector Pin-Out		Pin Side View
19820 Connector	Drive Terminology	
1	Clock +	
2	Up Sense	
3	-	
4	-	
5	Data -	
6	Data	
7	-	
8	Clock -	
9	-	
10	0V	
11	-	
12	Up	
Actuator Case	-	

Mfg's Cable Part Number- Stober Absolute Encoder Cable

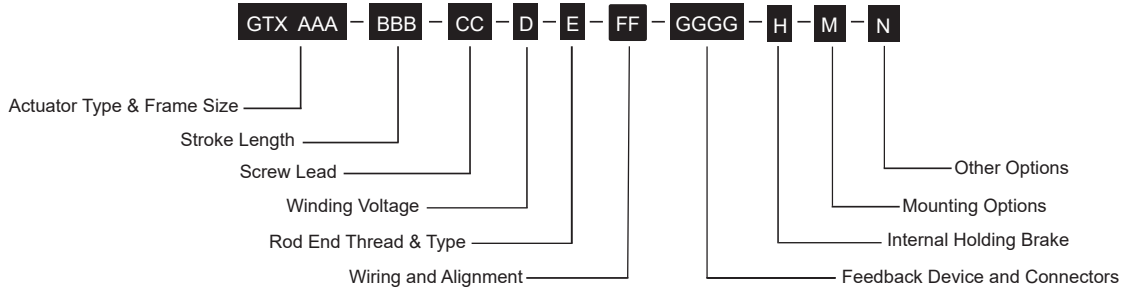

AAA = GTX Integrated Motor / Actuator

- 060 = 60 mm (2.36 in)
- 080 = 80 mm (3.15 in)
- 100 = 100 mm (3.94)

BBB = Stroke Length

- 080 = 80 mm (GTX060)
- 100 = 100 mm (GTX060, GTX080)
- 150 = 150 mm
- 300 = 300 mm
- 450 = 450 mm (GTX080)

CC = Screw Lead

- 01 = 2.54 mm (0.1 in), Roller Screw
- 02 = 5.08 mm (0.2 in), Roller Screw
- 04 = 10.2 mm (0.4 in), Roller Screw (GTX060)
- 05 = 12.7 mm (0.5 in), Roller Screw (GTX080, GTX100)

D = Winding Voltage

- 4 = 460 VAC Max
- D = 48 VDC Max (GTX060, GTX080)

E = Rod End Thread & Type

- A = Male Metric
- B = Female Metric
- C = Male Metric, Splined²
- D = Female Metric, Splined²
- F = Female Standard
- G = Male Standard, Splined²
- H = Female Standard, Splined²
- L = Female Metric, 17-4 Stainless Steel
- M = Male Standard
- R = Male Metric, 17-4 Stainless Steel
- V = Female Standard, 17-4 Stainless Steel
- W = Male Standard, 17-4 Stainless Steel

FF = Wiring and Alignment

- AK = AMK
- BR = B&R Automation
- BD = Baldor
- BE = Beckhoff
- BM = Baumuller
- CT = Control Techniques / Nidec
- EU = Elau / Schneider
- EL = Elmo Motion Control
- EX = Exlar
- IF = Infranor
- IN = Bosch-Rexroth
- KM = Kollmorgan
- LS = LTI
- LZ = Lenze
- PC = Parker
- RA = Rockwell Automation
- SM = Siemens
- SB = Stober Drives

GGGG = Feedback Device and Connectors

See table below

H= Internal Holding Brake

- N = No Brake
- B = Internal Holding Brake, Electronically Released

M = Mounting Options

- N = None
- 1 = Front Flange, Metric
- 3 = Tapped Face, Metric
- 5 = Rear Clevis, Metric
- F = Front Flange, Standard
- C = Rear Clevis, Standard

N = Other Options

- N = None
- A = Anti-Rotate Assembly, External
- L = Limit Switch Housing/ Anti-Rotate Assembly¹

¹Switches sold separately

²Splined Rod (Internal Anti-Rotate) option reduces IP rating.



For options or specials not listed above or for extended temperature operation, please contact Exlar

Drive Manufacturer	Wiring & Alignment Code	Resolver	Incremental Encoder	SICK Hiperface Absolute Encoder	SICK Hiperface DSL Absolute Encoder	Heidenhain Endat 2.2 Absolute Encoder	Heidenhain DRIVE-CiIQ Absolute Encoder
AMK	AK	R1A1				H1A1	
B&R Automation	BR	R1A1				H1A2	
Baldor	BD	R1A1				H1A1	
Baumuller	BM	R1A1		S1A1		H1A2	
Beckhoff Automation	BE					H1A2, H3C2	
Control Technologies / Nidec	CT	R2B1	E1B2	S1B1		H1B2	
Elau / Schneider	EU			S1A1			
Elmo Motion Control	EL	R1B1	E1B2			H1B2	
Exlar	EX	R1A1	E1A2	S1A2		H1A2	
Infranor	IF	R1B2		S1B2			
Bosch-Rexroth	IN			S2D3		H1D3	
Kollmorgan	KM	R2A1	E1A2			H1A2	
LTI	LS	R2A1		S1A2			
Lenze	LZ	R1B1		S1B1			
Parker	PC	R1B1	E1B2			H1B2	
Rockwell Automation	RA		E1C2	S1C2	S3C0		
Siemens	SM	R1B1				H1B2	H2B5
Stober Drives	SB	R2A1				H1A1	

Warranty and Limitations of Liability

WARRANTY AND LIMITATION OF LIABILITY: Please see our warranty on our website here: [Division Policies | About | Actuation Division | Curtiss-Wright Actuation Group \(cw-actuation.com\)](#) for details.

USA & CANADA

Exlar Automation
18400 West 77th Street
Chanhassen, MN 55317
Phone: 855-620-6200 (US & Canada)
Fax: 952-368-4877

ASIA

Exlar Asia Pacific
1007 Pine City Hotel
8 Dong An Road, Xuhui District
Shanghai 200032 China
Phone: +86 021-6495-7868

Distributed by:



www.exlar.com

Exlar® actuators are a brand of Curtiss-Wright, Actuation Division.