



**DC and EC motors –
the right drive for
your application**



excellent drives

Content

KAG excellent drives – made in Germany	4
Our portfolio.....	5
DC and EC motors	6
Customised drive solutions	7
Dimensions.....	8
Mechanical fitting.....	8
Specific winding.....	9
Individual wiring.....	9
Protection classes.....	9
Smart electronics for your drive application	10
Accessories.....	11
Planetary gearboxes.....	11
Worm gearboxes and spur gearboxes.....	12
Magnetic encoders.....	13
Optical encoders.....	14
Brakes.....	15
Your selection options	16
Our Contribution	22
To agricultural technology.....	22
To access automation.....	22
To medical technology.....	23
To barrier-free bus and rail technology.....	23
More information.....	24

KAG excellent drives – made in Germany

For 40 years, KAG has been perfecting sophisticated, customer-specific and always reliable drive solutions for DC motors from 2.5 to 250 watts and has established itself as one of the world's leading manufacturers in this sector.

We offer cost-effective and innovative drive concepts based on decades of experience and on the steadily expanding knowhow of our development engineers – tailored to your needs if required.

Wide selection of variants and accessories

Our focus is on developing and producing compact, versatile DC and EC drives that are customised to individual applications. Thanks to the extensive expertise of our development department we can offer you exactly the right solution for your specific application.



Your system supplier for complete solutions

Thanks to our modular facilities we are able to economically produce medium (up to 20,000), large (up to 200,000) and even, upon request, very small (50 – 500) quantities. We employ lean manufacturing techniques in production cells as well as fully automated production lines.

A driving force just like our motors

In order to bring you the best possible solutions we bring special personal resources to the table: passion for technical innovation, a high level of initiative and goal-driven commitment.

In addition to the state-of-the-art environment of our engineering and development department, our test laboratory plays a key role in the development cycle at KAG. Products that have to work perfectly are put to the test here. Digital microscopes, salt spray chambers, thermal and acoustic cameras as well as temperature, climatic and Pre-Compliance EMV test cabinets are used during the design and testing stage.

Our customers' satisfaction is our source of pride. It encourages us to produce customised products of the highest KAG quality – perfection to meet all your demands.

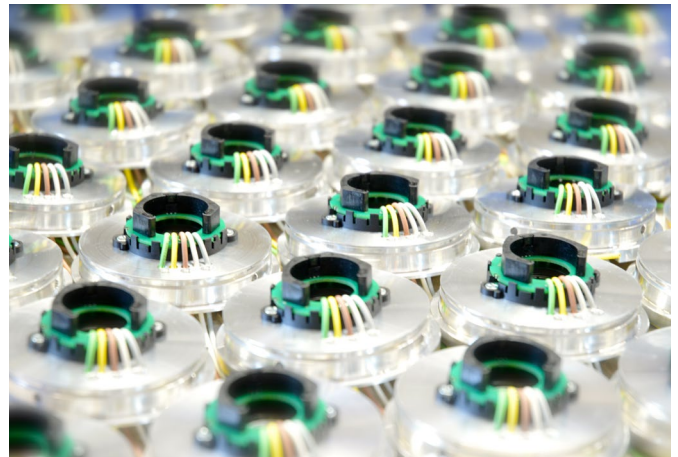

Our portfolio

We deliver motors that are individually customised to your special requirements to keep the entire spectrum of your options open to you.

In addition, we offer proven standard series for almost every purpose, always available at short notice.

DC and EC motors with intelligent electronics

Whether robust, brushed DC motors or extremely durable brushless EC series: What is special about the KAG range is that numerous motors are available with intelligent electronics. Our extensive experience covers a wide range of applications – ideal for adapting our motors to all application conditions.

Accessories

To complete your selected drive solution, we offer a wide selection of planetary, worm and spur gearboxes as well as magnetic and optical encoders and brakes.

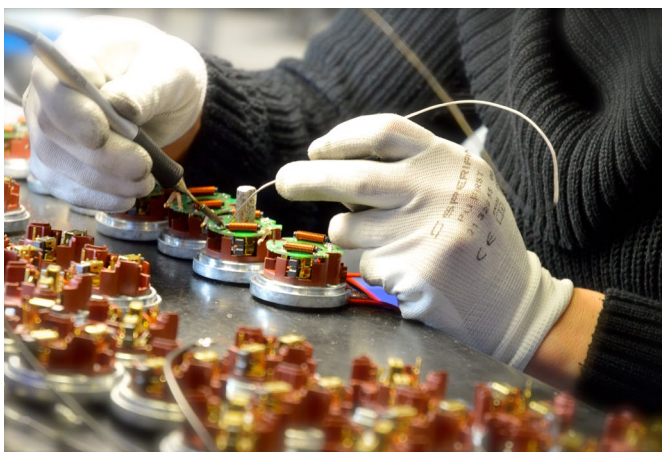
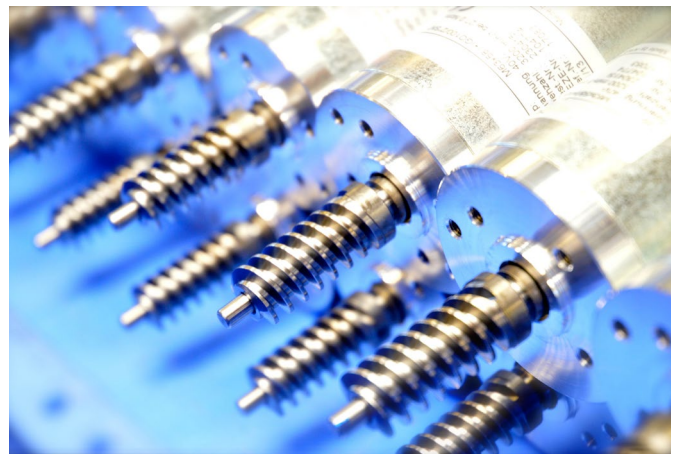
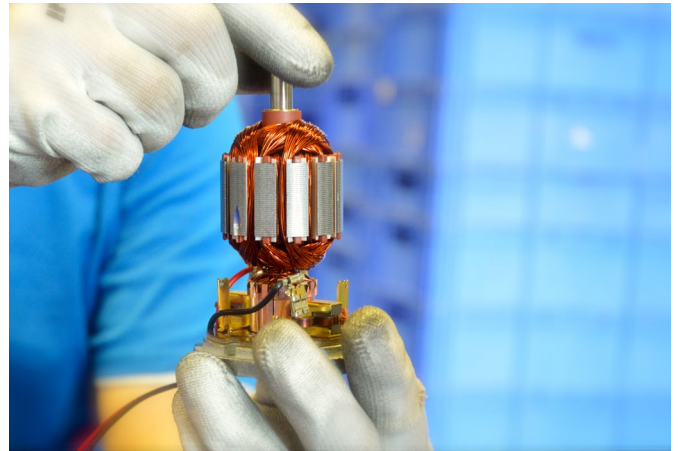

Our strengths

- Consulting service
- Realisation of special customer requests
- Innovative energy
- Promptness regarding tender preparation and prototype construction
- Flexibility even with complex logistics services
- Made in Germany

DC motors

Our standard series of DC (brushed) and EC (brushless) motors form the basis for numerous application solutions and drive combinations.

Our standard range of brushed DC motors currently comprises seven standard diameter, with intelligent

electronic control on request.

The brushless drives in the EC range (ECM = Electronically Commutated Motor) are available in five standard diameters. See detailed overview from page 16.

DC motors - performance overview at 3.000 rpm

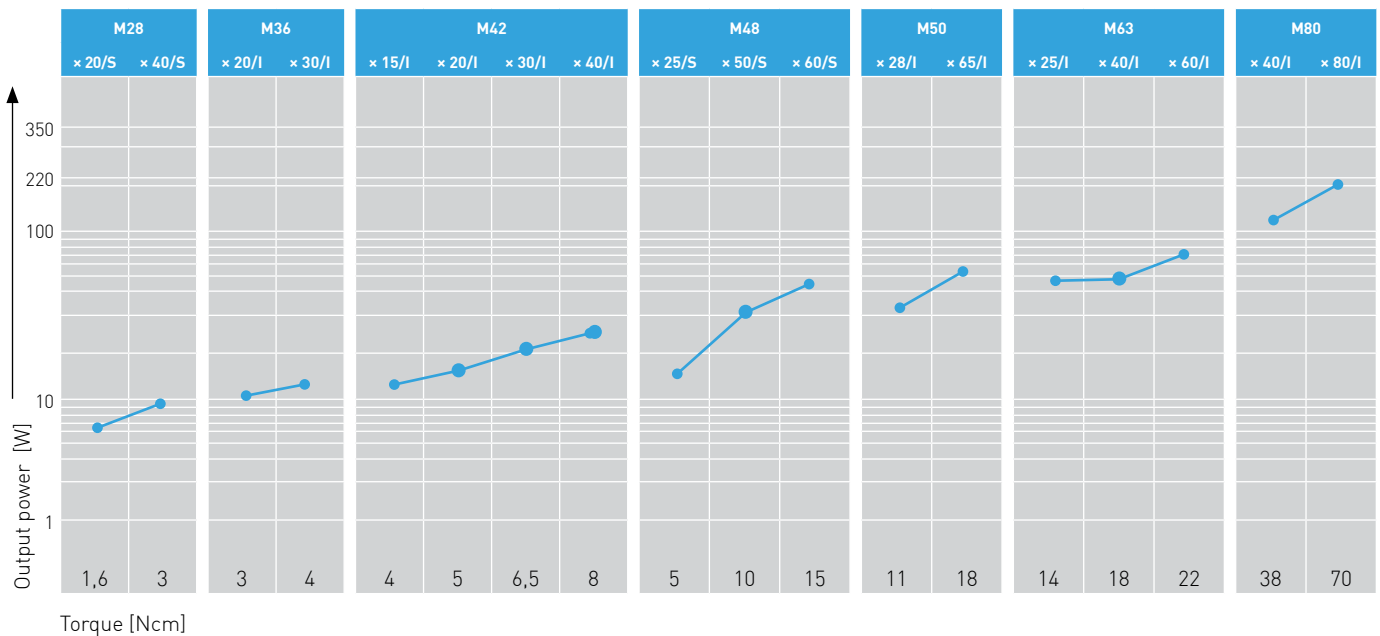

EC motors - performance overview at 3.000 rpm

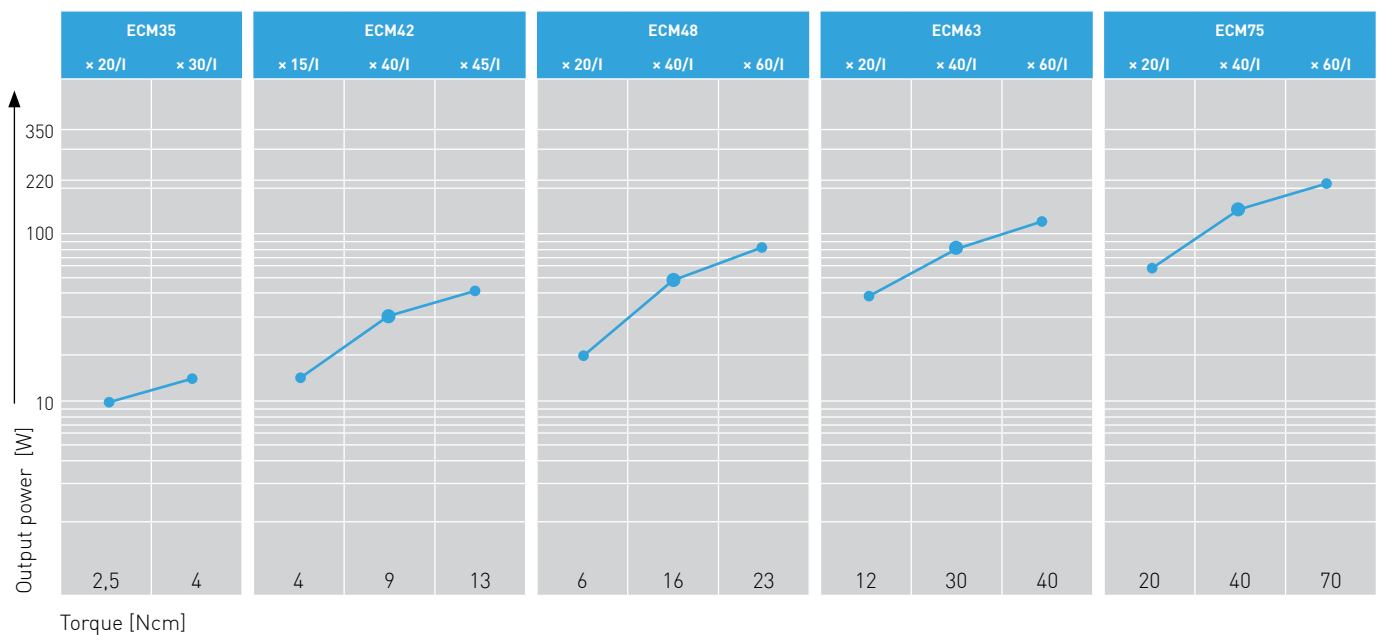

Customised drive solutions

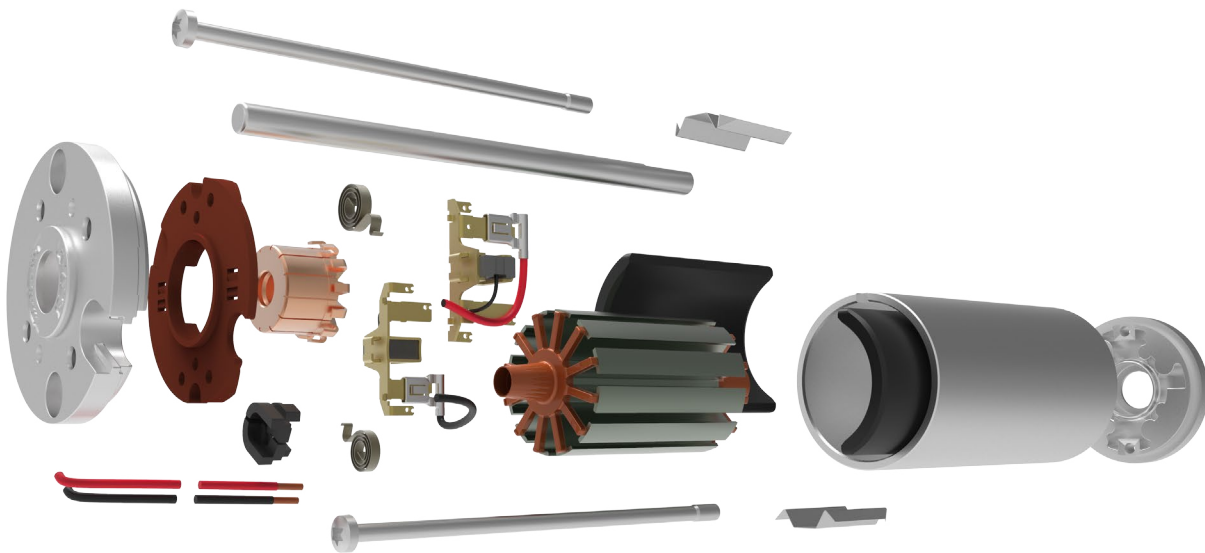

We develop, manufacture and supply to our customers individually adapted drives that are tailored to their needs. The advantage: The motor is adapted to your application and environment – and not your application to the motor.

We will meet all your requirements and provide the right motor for you. Our custom drives can pave the way for you to meet important environmental regulations, improve your economic performance or adapt to space constraints without losing functionality.

Tailor-made to all requirements

- Electrical parameters according to requirement
- Space optimisation
- Mechanical parameters according to requirement
- Environmental protection
- Noise and temperature control
- Energy efficiency
- Cost target



Dimensions



We can adapt housings and interfaces exactly to your space conditions – making use of every millimetre. In this way, quality drive solutions can be implemented in smallest spaces and under difficult connection conditions.

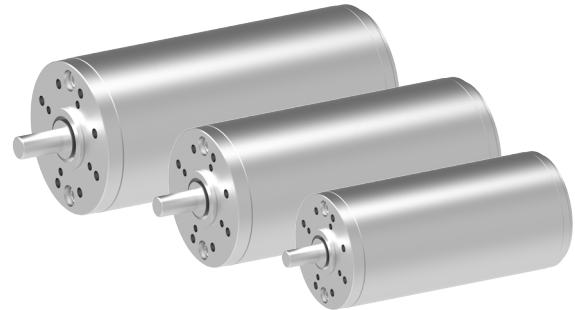

Mechanical fitting



Round shafts are the standard for our motors. Many variants are possible, such as stepped or flattened shafts, shafts with a borehole, tongue and groove and tothing.

The brushed motors can be equipped with RFI suppression circuits on request, also on circuit boards. During development, KAG can use its own EMC pre-compliance measurements to determine the optimal interference suppression variant.

The end shield can be made of die-cast zinc or turn milled aluminium. Special adapter plates and shapes of the end shield are also feasible. This can help save space as well as costs for the drive solution as required.

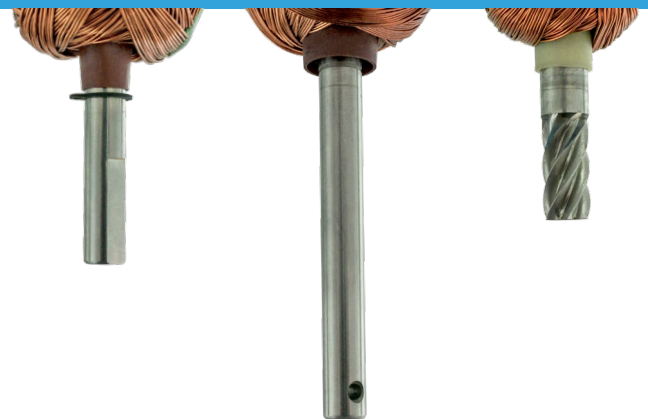

Individual winding



The number of windings and the wire diameter on KAG motors can be customised on request. Skewed armatures are more expensive to manufacture, but support a high control range, lower speed and lower cogging torque, helpful for doors that have to be opened by hand in an emergency.

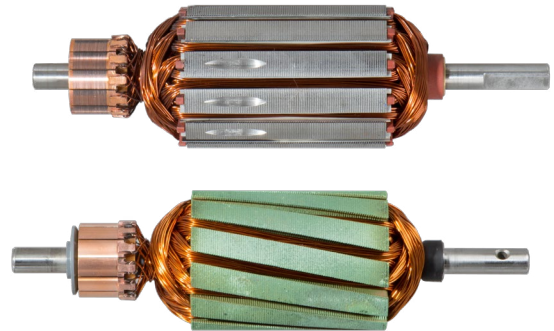

Individual wiring



The wiring for power supply and control can be modified almost infinitely if desired, from single strands to entire cable harnesses.

In cooperation with our partner company KEG Kählig Elektrotechnik GmbH we can provide special cable technology solutions for special areas of application.



Protection classes



Our standard motors are regularly protection class IP 40 (brushed motors) or IP 50 (brushless motors). Protection classes up to IP 69 can be implemented according to your requirements.

Our individual drive solutions can also be provided with an exterior coating according to customer requirements.



Smart electronics for your drive application

For several years now, KAG has been producing hardware and software solutions for our own EC and DC series to support the customer in precisely these areas.

implementation of customer-specific adjustments to the firmware. All of our electronic systems permit communication with the CAN-bus via various protocols.

High flexibility and a broad range of possible uses characterise the KAG motor solutions. So does quick

Overview of our integrated electronic systems

Circuit	i42	i42DC	i42LC	i63	i63DC	i75	i80DC
Max. voltage	30 V	30 V	30 V	30 V	30 V	30 V	30 V
Min. voltage	9 V	9 V	9 V	9 V	9 V	9 V	9 V
Max. current	5 A	5 A	2,6 A	10 A	10 A	15 A	20 A
Max. current peak	50 A	50 A	5 A	70 A	70 A	65 A	80 A
Nom. voltage	12 – 24 V	12 – 24 V	12 – 24 V	12 – 24 V	12 – 24 V	12 – 24 V	12 – 24 V
Operation type	4 Q	4 Q	2 Q	4 Q	4 Q	4 Q	2 Q
For motor sizes	ECM42, ECM48	M42, M48, M50	ECM42	ECM63	M63	ECM75	M80

Firmware

The standard firmware for all electronic systems provides precise control of speed and position. Other requirements can be programmed customer-specifically by KAG.

Examples of implemented customer requirements:

- Motor speed control for single-grain sowing unit
- Valve control actuated via digital inputs
- Automatic door control with temperature monitoring
- Target position generator: Calculation of motor position according to customer-specific framework conditions
- Speed control according to sensor input
- Input of light barrier impulse signals
- Reading a load balance via analogue inputs
- Input of an external speed impulse

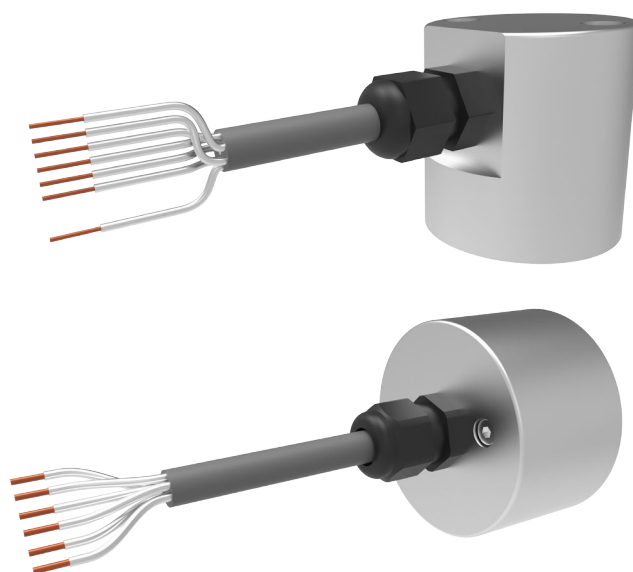

Accessories



Available accessories for your KAG drive solution include planetary, worm and spur gearboxes as well as magnetic and optical encoders and brakes in a wide selection.



Planetary gearboxes

- Steel housing, aluminium flange (PKS30, PK42, PK52: plastic)
- Great variety of gear ratios
- Multi-stage gears
- Adjustment of output shaft
- For more information, please see the specific data sheets

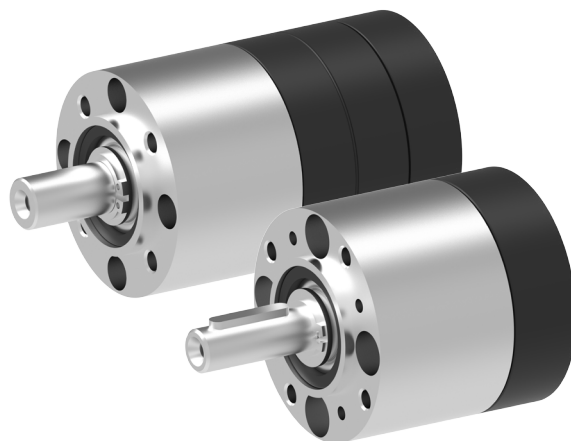

Overview of planetary gearboxes

	PKS30	P32	PK42	P42	PK52	P52	P62	P81
M28	x	x						
M36		x						
M42		x	x	x	x	x		
M48			x	x	x	x		
M50			x	x	x	x		
M63					x	x	x	x
M80							x	x
ECM35		x		x				
ECM42		x		x		x		
ECM48		x		x		x		
ECM63					x	x	x	
ECM75						x	x	

Worm gearboxes

- Suitable for left and right-hand rotation in alternating, continuous and intermittent operation
- Optional adjustment of output shaft
- Optional double-sided shaft outlet
- Optional plastic toothing at $i = 10:1$ and $15:1$ for SN31 and SN40
- For more information, please see the specific data sheets

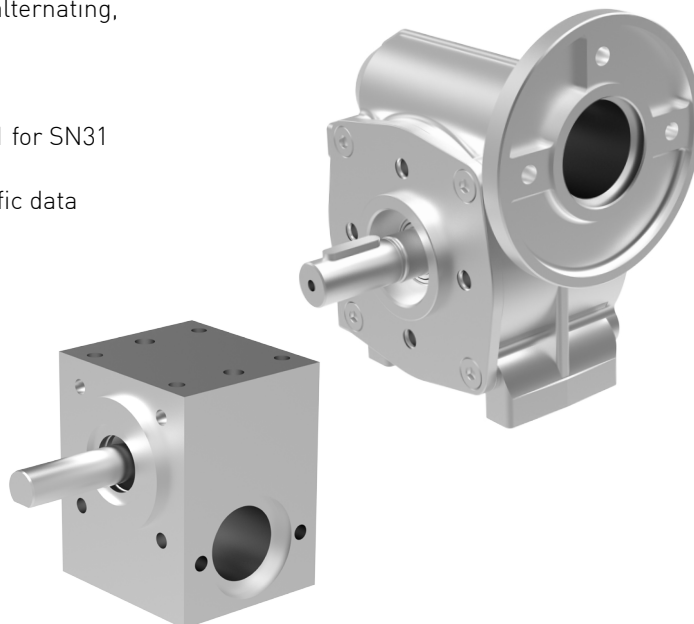

Spur gearboxes

- Plate gear or cast housing
- Nitrided steel gears
- Steel output shaft
- Output in sintered bronze bearings
- For more information, please see the specific data sheets

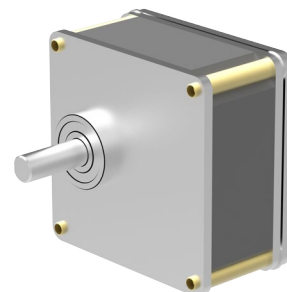

Overview of worm gearboxes

	SN17	SN22,6	SN31	SN40
M28				
M36				
M42	x	x		
M48	x	x	x	
M50	x	x	x	
M63			x	x
M80				x
ECM35				
ECM42	x	x		
ECM48	x	x	x	
ECM63			x	x
ECM75				x

Overview of spur gearboxes

	S1	S5	S8
M28	x		
M36			
M42		x	
M48		x	x
M50		x	x
M63			x
M80			

Magnetic encoders

- Touchless and wear resistant magnetic incremental encoder
- Symmetric amplitude corresponding to supply voltage
- Open collector output
- Integrated pull-up resistors
- Operating voltage = 4,5V - 24V
- Integrated design (IGMi) possible
LineDriver function possible (LD)
- For more information, please see the specific data sheets

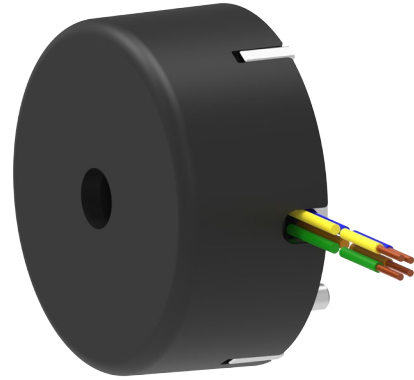

Overview of magnetic encoders

	IGM x/y	IGM x/y LD	IGMi
M28			
M36			
M42	x	x	x
M48	x	x	x
M50	x	x	x
M63	x	x	x
M80	x	x	x
ECM35			
ECM42	x	x	
ECM48	x	x	
ECM63	x	x	
ECM75	x	x	

Optical encoders

- Touchless and wear-resistant optical incremental encoder
- Supplies 2 quadrature, TTL-compatible channels with phase 90° (IGO x/2 SN 110°)
- Connectors e.g. Molex plug 5-pole type 5051 with contacts type 2759
- Optional: reference pulse
- Operating voltage = 5V
- For more information, please see the specific data sheets

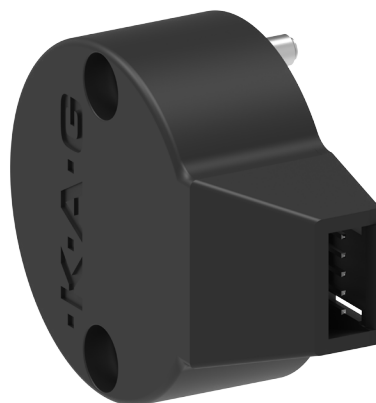

Overview of optical encoders

	IGO x/2	IGO x/3	IGO x/2 SN	IGO x/2 RU
M28				x
M36				x
M42	x	x	x	
M48	x	x	x	
M50	x	x	x	
M63	x	x	x	
M80	x	x	x	
ECM35				
ECM42	x	x		
ECM48	x	x		
ECM63	x	x		
ECM75	x	x		

Spring-applied brakes - B

- Electromagnetic fail-safe spring-applied brake / power-off brake
- Chromated coil housing
- Insulation class F
- Operating voltage = 24V (special voltage on request)
- For more information, please see the specific data sheets

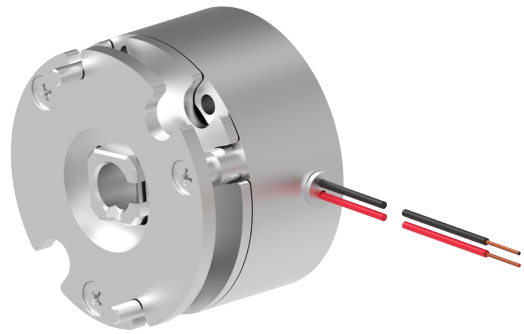

Power-on brakes - ASB

- Electromagnetic operating current brake / power-on brake
- Chromated housing
- Insulation class E
- Protection class IP40
- No twisting and cogging torque
- Operating voltage = 24V (special voltage on request)
- For more information, please see the specific data sheets

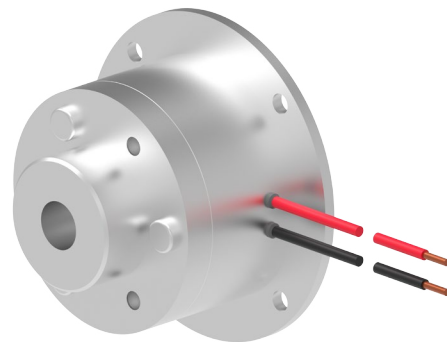

Overview of brakes

	B37	B47	B56	B60	ASB32	ASB40	ASB43
M28							
M36							
M42	x	x			x		
M48		x			x		
M50		x			x		
M63		x	x	x	x	x	x
M80		x	x	x		x	x
ECM35							
ECM42	x	x			x		
ECM48		x			x		
ECM63		x	x	x	x	x	x
ECM75			x	x		x	x

Your selection options

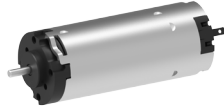

		M28				M36			
		× 20/S	× 20/S	× 40/S	× 40/S	× 20/I	× 20/I	× 30/I	× 30/I
Ident. no.		220518	220519	220520	220521	220220	220221	220222	220223
Voltage [V]		12	24	12	24	12	24	12	24
Torque [A]		1,6	1,6	3	3	3	3	4	4
Speed [min ⁻¹]		3.150	3.000	3.100	3.100	2.900	2.900	3.400	3.200
Motor length [mm]		50	50	70	70	60	60	70	70
Shaft diameter [mm]		3m3	3m3	3m3	3m3	4k5	4k5	4k5	4k5
Shaft length [mm]		12	12	12	12	20	20	20	20
Planetary gearboxes [Ncm]	PKS30	28 - 250	28 - 250	52 - 250	52 - 250				
	P32	5 - 345	5 - 345	9 - 450	9 - 450	9 - 450	9 - 450	12 - 450	12 - 450
	PK42								
	P42								
	PK52								
	P52								
	P62								
	P81								
Worm gearboxes [Ncm]	SN17								
	SN22,6								
	SN31								
	SN40								
Spur gearboxes [Ncm]	S1	9 - 120	9 - 120	16 - 120	16 - 120				
	S5								
	S8								
Electronic	i42DC								
	i63DC								
	i80DC								
Magnetic encoders	IGM x/y								
	IGM x/y LD								
	IGMi								
Optical encoders	IGO x/2								
	IGO x/3								
	IGO x/2 SN								
	IGO x/2 RU	×	×	×	×	×	×	×	×
Spring-applied brakes	B37								
	B47								
	B56								
	B60								
Power-on brakes	ASB32								
	ASB40								
	ASB43								

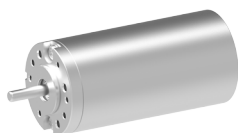

M42							
× 15/l	× 15/l	× 20/l	× 20/l	× 30/l	× 30/l	× 40/l	× 40/l
211112	211113	211100	211101	211102	211103	211220	211221b
12	24	12	24	12	24	12	24
4	4	5	5	6,5	6,5	8	9
3.000	3.250	3.300	3.400	3.300	3.100	3.150	3.000
70	70	75	75	85	85	95	95
5k5	5k5	5k5	5k5	5k5	5k5	6k5	6k5
20	20	20	20	20	20	20	20
12 - 450	12 - 450	15 - 450	15 - 450	20 - 450	20 - 450	27 - 450	27 - 450
12 - 400	12 - 400	15 - 400	15 - 400	20 - 400	20 - 400	27 - 400	27 - 400
12 - 862	12 - 862	15 - 1.078	15 - 1.078	20 - 1.400	20 - 1.400	27 - 1.500	27 - 1.500
11 - 800	11 - 800	14 - 1000	14 - 1000	18 - 1000	18 - 1000	25 - 1000	25 - 1000
12 - 862	12 - 862	15 - 1.078	15 - 1.078	20 - 1.400	20 - 1.400	24 - 1.725	27 - 1.940
28 - 93	28 - 93	35 - 117	35 - 117	45 - 152	45 - 152	55 - 210	55 - 210
20 - 155	20 - 155	25 - 194	25 - 194	32 - 282	32 - 282	40 - 349	40 - 349
29 - 500	29 - 500	37 - 500	37 - 500	47 - 500	47 - 500	66 - 500	66 - 500
×	×	×	×	×	×	×	×
×	×	×	×	×	×	×	×
×	×	×	×	×	×	×	×
×	×	×	×	×	×	×	×
×	×	×	×	×	×	×	×
×	×	×	×	×	×	×	×
×	×	×	×	×	×	×	×
×	×	×	×	×	×	×	×
×	×	×	×	×	×	×	×
×	×	×	×	×	×	×	×

Your selection options



	M48						M50	
	× 25/S	× 25/S	× 50/S	× 50/S	× 60/I	× 60/I	× 28/I	× 65/I
Ident. no.	210890	210891	210892	210893	220191	211333	223908	223907
Voltage [V]	12	24	12	24	12	24	24	24
Torque [A]	5	5	10	10	15	15	11	18
Speed [min ⁻¹]	2.800	2.800	3.050	3.150	3.000	3.300	2.800	2.900
Motor length [mm]	91	91	116	116	126	126	91	126
Shaft diameter [mm]	5k5	5k5	5k5	5k5	6k5	6k5	6k5	6k5
Shaft length [mm]	20	20	20	20	20	20	20	20
Planetary gearboxes [Ncm]	PKS30							
	P32							
	PK42	15 - 400	15 - 400	30 - 400	30 - 400	45 - 400	45 - 400	
	P42	15 - 1.078	15 - 1.078	30 - 1.500	30 - 1.500	45 - 1.500	45 - 1.500	32,5 - 1.500
	PK52	14 - 1000	14 - 1000	28 - 1000	28 - 1000	42 - 1000	42 - 1000	
	P52	15 - 1.078	15 - 1.078	30 - 2.156	30 - 2.156	45 - 2.500	45 - 2.500	32,5 - 2.371
		53 - 2.500						
Worm gearboxes [Ncm]	P62							
	P81							
	SN17	35 - 158	35 - 158	69 - 300	69 - 300	103 - 300	103 - 300	
	SN22,6	25 - 194	25 - 194	44 - 388	44 - 388	75 - 500	75 - 500	55 - 426
	89 - 500							
	SN31	24 - 165	24 - 165	48 - 330	48 - 330	72 - 496	72 - 496	53 - 363
	87 - 594							
	SN40							
Spur gearboxes [Ncm]	S1							
	S5	37 - 500	37 - 500	73 - 500	73 - 500	110 - 500	110 - 500	73 - 500
	S8	131 - 800	131 - 800	262 - 800	262 - 800	394 - 800	394 - 800	262 - 800
	446 - 800							
Electronic	i42DC	×	×	×	×	×	×	×
	i63DC							
	i80DC							
Magnetic encoders	IGM x/y	×	×	×	×	×	×	×
	IGM x/y LD	×	×	×	×	×	×	×
	IGMi	×	×	×	×	×	×	×
Optical encoders	IGO x/2	×	×	×	×	×	×	×
	IGO x/3	×	×	×	×	×	×	×
	IGO x/2 SN	×	×	×	×	×	×	×
	IGO x/2 RU							
Spring-applied brakes	B37							
	B47	×	×	×	×	×	×	×
	B56							
	B60							
Power-on brakes	ASB32	×	×	×	×	×	×	×
	ASB40							
	ASB43							

Your selection options

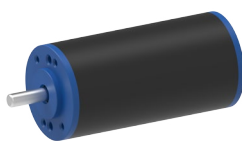

		ECM35			ECM42		ECM48		
		× 20/l	× 30/l	× 15/l	× 40/l	× 45/l	× 20/l	× 40/l	× 60/l
Ident. no.		230543	230544	230528	230527	230488	230546	230547	230548
Voltage [V]		24	24	24	24	24	24	24	24
Torque [A]		2,5	4	4	9	13	6	16	23
Speed [min ⁻¹]		3.800	3.600	3.500	3.200	3.100	3.050	3.550	3.550
Motor length [mm]		72	82	70	85	100	80	100	120
Shaft diameter [mm]		4g5	4g5	6g5	6g5	6g5	6g5	6g5	6g5
Shaft length [mm]		20	20	20	20	20	20	20	20
Planetary gearboxes [Ncm]	P32	8 - 450	12 - 450	11 - 450	27 - 450	39 - 450	18 - 450	47 - 450	68 - 450
	P42	8 - 539	12 - 862	11 - 800	27 - 1.500	39 - 1.500	18 - 1.294	47 - 1.500	68 - 1.500
	PK52								
	P52			12 - 862	27 - 1.940	39 - 2.500	18 - 1.293	47 - 2.500	68 - 2.500
	P62								
Worm gearboxes [Ncm]	SN17			28 - 126	62 - 284	90 - 300	41 - 189	110 - 300	159 - 300
	SN22,6			20 - 155	45 - 349	65 - 500	30 - 233	74 - 500	114 - 500
	SN31						29 - 198	77 - 528	111 - 759
	SN40								
Electronic	i42			×	×	×	×	×	×
	i42LC			×	×	×	×	×	×
	i63								
	i75								
Magnetic encoders	IGM x/y			×	×	×	×	×	×
	IGM x/y LD			×	×	×	×	×	×
Optical encoders	IG0 x/2			×	×	×	×	×	×
	IG0 x/3			×	×	×	×	×	×
Spring-applied brakes	B37			×	×	×			
	B47			×	×	×	×	×	×
	B56								
	B60								
Power-on brakes	ASB32			×	×	×	×	×	×
	ASB40								
	ASB43								



	ECM63			ECM75		
	× 20/l	× 40/l	× 60/l	× 20/l	× 40/l	× 60/l
230532	230531	230493	230549	230550	230551	
24	24	24	24	24	24	
12	30	40	20	40	70	
3100	2.600	2.850	2.750	2900	3.000	
90	110	130	101,5	121,5	141,5	
8g5	8g5	8g5	10g5	10g5	10g5	
25	25	25	30	30	30	
33 - 1000	83 - 1000	111 - 1000				
36 - 2.500	89 - 2.500	118 - 2.500	59 - 2.500	118 - 2.500	207 - 2.500	
36 - 2.587	89 - 5.000	118 - 5.000	59 - 4.312	118 - 5.000	207 - 5.000	
58 - 396	145 - 990	193 - 1200				
89 - 378	222 - 945	296 - 1260	148 - 630	296 - 1260	518 - 2205	
×	×	×				
			×	×	×	
×	×	×	×	×	×	×
×	×	×	×	×	×	×
×	×	×	×	×	×	×
×	×	×				
×	×	×	×	×	×	×
×	×	×	×	×	×	×
×	×	×				
×	×	×	×	×	×	×
×	×	×	×	×	×	×

Our Contribution

... to agricultural technology

Our drives for agricultural technology help secure the future supply with agricultural goods. KAG-drives are designed specifically for the rough areas in agriculture. The motors, usually designed for 12 V, have high degrees of protection, which makes it possible to use them outdoors easily and also allows cleaning them with high pressure water.

Special surface refinement protects the drives from aggressive media, such as fertilisers or hydraulic oil. To meet the request of digitalisation in agriculture, we have dealt with decentralized, bus-capable drives early on and now offer diverse solutions.

Use of special cables, such as hybrid cables with robust connectors in high protection class simplify connecting enormously and are ready to face nearly any demand. On request, the drives can be painted to the customers CI colours and specifications.

- In seeding and harvesting machines
- In fertiliser and granulate spreaders
- In potato planting machines



... to access automation

We can no longer imagine our everyday lives without automatically opening doors and turnstiles. No public building would go without automated door technology today. The trend to increased comfort grows stronger in private areas as well. Reliable and space-saving drive systems must be provided for this.

Our solutions offer high functional safety by reduction of the resetting torques, e.g. in rotary door drives and other automatic doors, as well as better protection against damage by vandalism. Thermal monitoring elements and switches serve continuous protection of the system.

High protection types make additional casings unnecessary.

- In lift doors, rotary doors and automatic doors
- In person separators and passage barriers
- In room separating walls, etc.



... to medical technology

Health requires medicine technology. Due to demographic change, innovative medicine-technology devices are needed more and more. The needs of the aging society increase and demand simple and reliable, as well as comfortable, solutions. This leads to new demands to drive technology.

From rescue to preserving human lives to restoration of health, we are represented in a great many different applications with our motors and drive solutions.

Good control properties within a larger control area and a high efficiency of our drives ensure availability and performance of medical systems. Complex integrated EMC filters for compliance with strict standards in medicine technology. Mobile systems remain usable for longer periods of time thanks to the low current consumption of our drives and the connected longer battery service lives.

- In pumps, dialysis devices and centrifuges
- In person lifters and stair lifts
- In operating tables, etc.



... to barrier-free bus and rail technology

The legislators demand accessible entrance in public transport such as train or buses. Automatically opening doors or entrance helps like sliding steps: Increasingly sophisticated systems for increased safety, comfort and integration become the general standard in equipment of often-used means of transport.

OEMs and operators make use of the decades of experience KAG has in the area of drive systems for bus and train technology. Our drives for use in bus and train are designed for a high vibration resistance. In our climate cabinets, we also review reliability of the drives in light of extreme environmental conditions.

Required operating cycles are reviewed for supporting your TÜV acceptance.

- In bus and railway doors
- In ramps and steps
- In sanding systems and switchgear
- In mirror adjustments

More information

Would you like to know more or do you need further information on the individual application areas for KAG motors?

See our application brochures for agricultural technology, medical technology, access automation und barrier-free

bus/rail technology for the key facts about the respective scope of performance of our motors in your area of application. We will gladly send you our brochures on request.

We will be pleased to answer your questions and requests personally at any time.



For 40 years, KAG has been perfecting sophisticated, customer-specific and always reliable drive solutions for DC motors from 2.5 watts. Our service model is characterised by speed and flexibility as well as high customer orientation.

Kählig Antriebstechnik GmbH

Pappelweg 4
30179 Hannover / Germany
Phone: +49 (0) 511 67493-0
Fax: +49 (0) 511 67493-67
info@kag-hannover.de

www.kag-hannover.de